



# Learn Magic!



With Jim Stott



## About The Author

Jim has been successfully entertaining children and adults with his magic since 1976. With over 35 years of experience, he knows and understands his audiences. With six kids and twelve grandkids, Jim knows children. Add to that his experience as a teacher, principal, and school superintendent and you know that you will be in good hands if you have Jim entertain at your next party or event.

Jim and his wife, Diane, live in Kuttawa, Kentucky. In addition to their magic, Jim and Diane keep busy with their two companies, *Bayview Properties, LLC* and *Woodside Properties, LLC*. In addition, Jim is the president of the Lake Barkley Chamber of Commerce and Diane volunteers her time with the *Rivers Bend Retirement Home* in Kuttawa.

Jim not only performs magic but teaches other magicians how to entertain successfully as well. He is the author of [Birthday Magicology](#), which is a twelve week course teaching magicians how to achieve success in performing birthday parties and [Restaurant Magicology](#), which teaches magicians how to perform successfully in restaurant settings.

Jim is a member of the *Society of American Magicians*, *Kidabra*, and the *International Brotherhood of Magicians*. He is a two-time president of the *Society of American Magicians Jay Marshall Assembly #148* in Chicago.

To learn more about Jim, visit his website at:

[www.JimStottMagic.com](http://www.JimStottMagic.com)

# Jim Stott's

## Helpful Hints... PRACTICING

Make practice easier by setting aside a certain time each day, maybe just after dinner, for practicing your tricks and routines.

Keep going for about 15 minutes, then stop for about 5 or 10 minutes. This would be a good time to think about the kind of story you'll tell when you do the trick.

Now practice the same trick again for another 15 minutes. You'll find the moves are easier to do after that short break.

It's a good idea to practice the trick and the story you'll tell at the same time.

When you perform a routine in front of people, you may be nervous. This is normal. However, when you have practiced the routine as much as possible, you won't be quite as nervous, because you'll have a better idea of what's going to happen.



# Rules for Good Magicians

**SECRETS:** Never, never tell your friends how you did a trick; no matter how much they ask. Once they learn the secrets, all the fun is gone. When they ask, be polite and say "I promised never to tell", or "I don't know how it works myself!"

**REPEATING:** Never do the same trick again right away. When your friends say "Do that again", it means they were fooled, but this time they'll catch you. If you do it again, their eyes will be watching every move. If they insist, do a different trick.

**BOASTING:** Don't boast about how good you are. This will make your friends angry at you, and they won't watch another trick. It's not fun knowing magic if people don't watch. So when the magic trick happens, act surprised.

**PRACTICE:** Practice each trick many times before you show it to anyone. If you show it without practicing, you'll just give the secret away or have the trick fail. If you do mess up a trick in front of an audience, just go on to another trick.

**MIRRORS:** Always think about how the trick will look to the audience. The best way is to practice in front of a mirror, so you can see what your friends will see. They will watch closely, so you must know how it looks to them. Sometimes you will see things that surprise you.

**TRICKS:** Choose the tricks you like best. Nobody could do every trick equally well. As you try new tricks, some will "feel" right for you, while others won't. Stick to the ones that feel right, and you will do them the best.

# "Forcing" a Card

Making the spectator pick the card YOU want, while they think they're picking the card THEY want.

## The Cut Force

Before starting the trick, secretly remember the top card of the deck. This is the "force card" that you will force your friend (the spectator) to choose, although s/he will think it is a free choice.

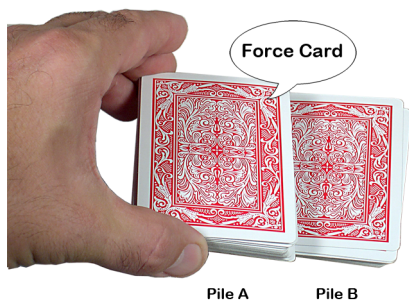

Have the spectator lift up half the deck, and place it on the table. This is called cutting the deck.

You now have two piles of cards, A and B. The card your friend will choose, the force card, is on the top of pile A. Keep track of where the force card is, and don't forget it.

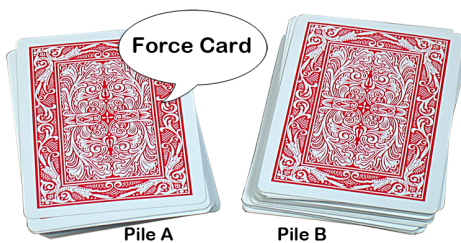

Tell the spectator you will mark where the cut was. Pick up pile B, and place it sideways on top of pile A. The pictures show how this is done.

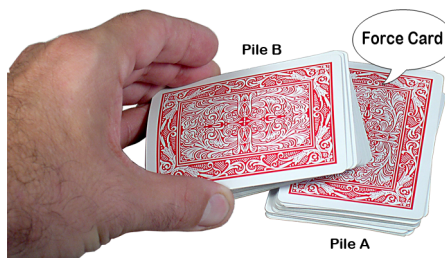

Ask the spectator if s/he has seen the card yet, and when s/he says no, lift pile B, and have the spectator take the top card of pile A. Your friend will think this is where s/he cut the deck of cards, so when the card is picked up, they will think it is their card.

## The Scarf Force

Once again, secretly remember the top card of the deck. You will also need a scarf that you cannot see through. Hold the deck in your hand, and drape the scarf over it.

Here comes the important move. Under cover of the scarf, turn the deck upside-down in your hand. The photos are shown without the scarf. The spectator can not see it, since the hanky is covering it up, so s/he will think it is normal.

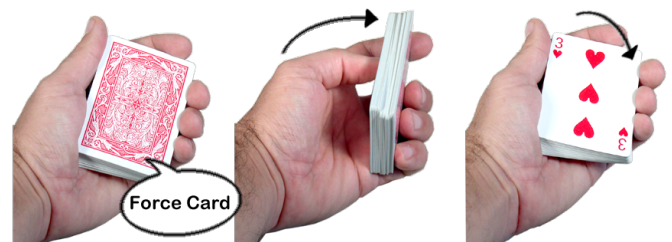

Now have the spectator lift up the top half of the deck.

Before the scarf uncovers your hand, turn the bottom half of the deck right-side up.

When the spectator takes the top card off the deck in your hand, s/he will think it is the chosen card

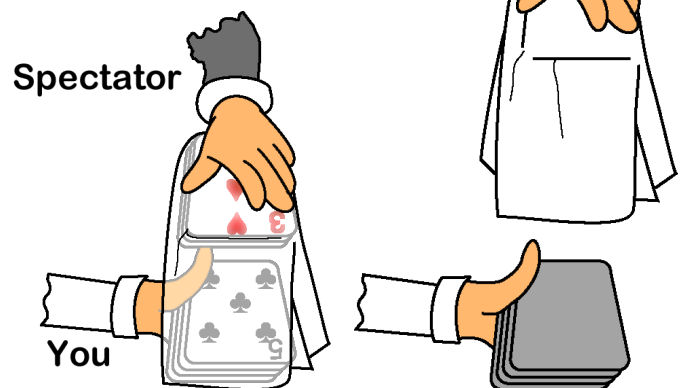

# Folding Paper Gimmick

A packet of folded newspaper is opened up, and inside is a yellow piece of folded paper. After opening that, a torn card is placed in it, then the yellow paper folded back up. Next the newspaper is wrapped around the yellow paper, and everybody says the magic words. When everything is unfolded, it is seen that the card has magically been restored!

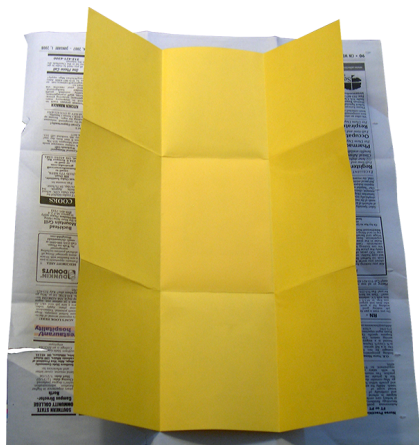
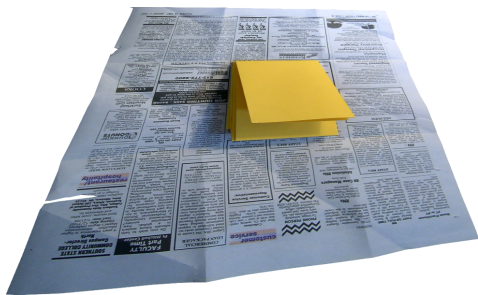

## The secret:

The yellow piece of paper is actually 2 pieces glued back to back. Each paper is folded in exactly the same way.

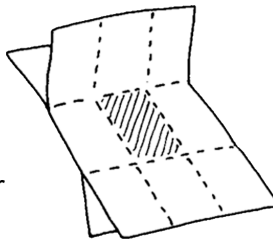

Folded into the back side is a whole card, which matches the torn card. You'll need to use 2 decks. Make sure you have permission before tearing cards.

When opening the newspaper and yellow paper, be careful not to show the back of the yellow paper. Nobody should know it's double sided. Don't lift up the yellow paper, keep it sitting on the newspaper.

Place the torn pieces in the center of the yellow paper. Have an audience helper tear the card, that will make the trick more interesting.

Carefully fold the yellow paper, while keeping it in the center of the newspaper. Now comes the secret move. While folding the newspaper, simply turn over the yellow paper. The large side of the newspaper will help to cover this move. Practice this move often so it will be done smoothly.

After the audience has helped by saying the magic words, open the newspaper, the yellow paper, and show the torn card has become whole again!

These folded papers are a very useful tool for switching one flat item for another. Restoring a torn card is just one of many ways it can be used.

You could turn a blank piece of paper into a dollar bill, or 5 one dollar bills into 1 five dollar bill. You could use it to vanish a card, or to make one appear.

It's also good to use because it folds up small and can be carried in your pocket, ready to use whenever needed.





## Helpful Hints... Buying Tricks

Going into a magic shop to buy a new trick is fun, but make sure you are prepared BEFORE you go. Remember, the person behind the counter doesn't know what kind of tricks you like, or what type of shows you do, so you need to tell them.

How much experience does the trick require? Some tricks are very difficult even for magicians with 20 years experience, so you should wait before buying them.

How much does it cost? Many tricks are quite expensive, and only do one thing. The best thing to buy, instead of a trick, is a book. In a magic book, you will find dozens, maybe hundreds of tricks. Sometimes you will find out how to make one of the tricks you saw in the store. This will save you some money.

Some tricks you will have to buy, because they are difficult to make yourself. Sponge balls, card vanish boxes, thumb-tips and linking rings are just a few examples.

Of course, always shop around for the best price.

# The Case of the Card in the Case

For this routine you'll need a deck of cards, one duplicate card, a way to vanish the card, and the card case (the box that the cards come in).

Here's what happens: The spectator picks a card, remembers it, and shows it to everyone. (It's ok if you see it). The card disappears, and reappears inside the card case, which was in full view at all times. This is a very strong routine, which people will remember for a long time.

How does it work? Have the duplicate card on top of the deck, inside the case. When you pull the deck out of the box, leave the duplicate inside. Keep the opening of the case towards you, so nobody sees you leave the card inside.

Lay the card case on the table, so everybody can see it. Have the spectator choose a card, but make sure s/he gets the card which matches the one in the case. You'll need to force the card.



Here is where you vanish the card, but don't say you're going to vanish it. Just say you'll wrap it up for safe keeping.

Now say the magic words, wave the wand, jump up and down, or whatever. Show that the card is gone, then point to the card case. Tell one of the spectators to open it, and show the card inside.

[www.JimStottMagic.com](http://www.JimStottMagic.com)



## Helpful Hints... Can You See This?

Audiences need to see what you are doing. If you are doing tricks for a few people, they can be small tricks you can fit in your pocket. When you do a show for a large crowd, make sure the tricks can be seen by everybody. Card tricks are difficult for a large group, because people sitting in the back will not be able to see well.

Adjust your voice to suit the crowd also. For a few people, you can just talk normal. For a large group, you will need to talk louder. Don't yell, however, just talk louder.

Always keep in mind what the audience will be seeing. When you show them something, hold it at your finger tips, so everyone can see it clearly. Watch people in TV commercials when they hold something. They make sure it's easy to see. This is one of the reasons why practicing in front of a mirror is so important.

# The Paper Bag Card Trick

For this routine you will need a paper bag that can easily fit over a person's head, a deck of cards, a duplicate card, and some sticky tape or rubber cement.

Have somebody choose a card out of the deck, and remember it. Then you toss the deck and the selected card into the paper bag, and shake them up. Tell everyone that you will reach into the bag and pull out the selected card. Pull one out, but it's the wrong one. Try again, but it's still wrong. Ask the spectator if s/he can find the card. Turn the paper bag upside down over the spectator's head. With the cards falling everywhere, ask if they've found it yet. Take the paper bag off their head, say "How could you miss it? It's the only card still in there", reach inside, and pull out the chosen card.

This is how it's done. Inside the paper bag is a duplicate card, stuck to the bottom with a small piece of tape or rubber cement. Not too much, though, because you'll need to pull the card out later. When the spectator chooses a card, you force the card that matches the one in the paper bag. From here on it's acting. When you pull out the wrong cards, act really disappointed.

Make sure the person who wears the paper bag is in a good mood. You can tell if they are before you start the routine.

When the routine is over, be certain to pick up the cards. Putting them back in the paper bag will make that easy.

Here is another idea. While looking in the bag for the chosen card, ask if it was red or black. Let's say it is red. When they answer red, pull out a card that is completely covered in red, with no numbers or anything showing. This should get a good laugh.

Here's how. Get the jokers, and with paint or marker, color them completely, then tape them in the bag next to the duplicate card.

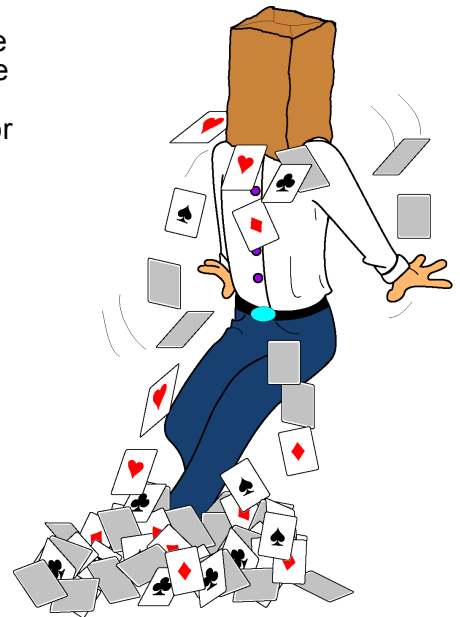

# The Short Card Key Card

Many card tricks start with somebody choosing a card, looking at it, then putting it back. You must find the card. This page will show you a way to do that! By using a short card, it is easy to find a chosen card. It takes a lot of PRACTICE, because you need to feel the card with your fingertips, and hear it with your ears.

A card is trimmed  $\frac{1}{16}$ th of an inch shorter than all the others. This may not seem like much, but it makes a big difference when you riffle the ends of the deck.

Next, using fingernail clippers, trim the corners so they match the other cards as closely as possible.

How do you riffle the cards? First, make sure the edges of the deck are perfectly flat. Tap it gently on a table to set them. Bend back one end of the deck. Don't bend them back too far, or you will not be able to riffle correctly. Softly let go of one card at a time. When you come to the short card, it will feel different, and if you are riffling correctly, it will automatically stop. You will also be able to hear the difference when you hit the short card.

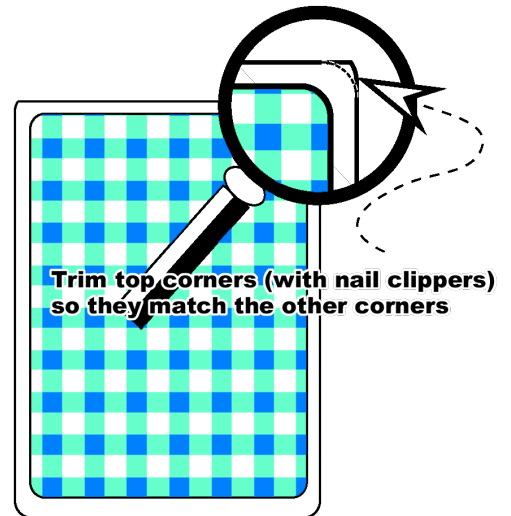

A way to make this trick even better is to let your helper cut the deck as often as they want after they have inserted the chosen card. The short card should stay on top of the chosen card. If your helper cuts the deck between the short card and the chosen card, then the chosen card will be on top of the deck, and the short card will be on the bottom. If that happens, just cut the deck one more time, and the chosen and short card will be together again.

Sometimes you may have trouble finding the short card. This usually happens when the short card is near the top or bottom of the deck. Just cut

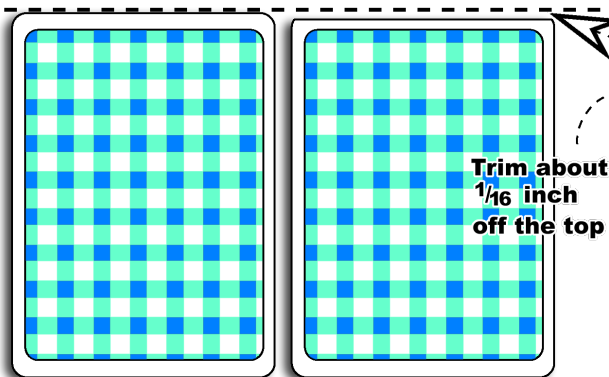

How do you use the short card to find a chosen card? Make sure the short card is on the bottom of the deck. Have a helper choose a card. Have him/her put the chosen card on top of the deck. Now tell him/her to cut the deck,

and place the bottom half on top of the other half. That automatically places the short card on top of the chosen card. Try it and see!

Finding it is easy now. Just riffle the cards until you come to the short card. The chosen card will be the next one down!



# The Upside-Down Card Location

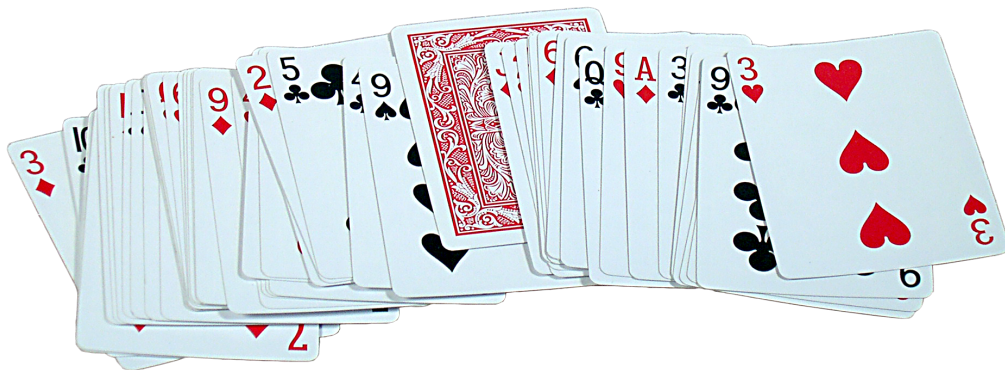

Ask a helper to choose any card from the deck. Show it around, then put it back in the deck. You try to find it, but can't. You spread the cards out, but one card is upside-down... it's the chosen card!

Here is how it works: Your helper picks any card s/he wants. If you want, the front of the card may be signed with a magic marker, so they can't forget the card. You then tell him/her to show the card to everyone, and to make sure you don't see it, you turn your back to the audience. Keep the deck of cards in your hands. Now comes the secret move.

Keep your elbows against your sides, so the audience can't see any movements from behind. Turn the deck upside-down, then turn the top card upside down. You now have a deck that looks normal even though it's actually upside-down.

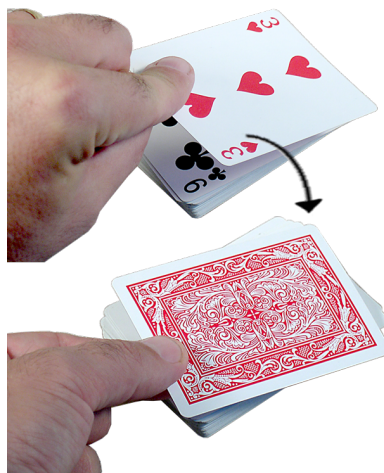

Announce you will find the card without looking, and hold the deck behind your back. Grab the top card (the one that's upside-down), show it to everyone, and ask if it was the chosen card. When they say no, look a little worried and say you'll try again.

Reach behind you and grab the next card, show it to everyone, and again they will say no. Now act like you really messed up the trick, and start spreading the cards apart like in the photo at the top of this page.

When you come to the upside down card, push it out onto the table, but keep your finger on it. Tell everybody that the chosen card has turned upside-down by magic.

Now ask your helper what the name of the card was, and when s/he says it, turn the card over and show it. Take a bow to the thunderous applause!



When you turn around, hold the deck in your hand just like it was before, and insert the chosen card into the deck. You've actually put the card into an upside-down deck, but the audience will think it's normal.





## Helpful Hints... Think Ahead & Be Prepared

As you perform more shows, things will go wrong, but if you're ready, they won't mess up your performance.

One time a magician was doing a cut and restored rope trick, and his helper, using a sharp pair of scissors, cut the magician's finger instead of the rope. What would you do if that happened?

The best thing to do is make sure it doesn't happen at all. How? Cut the rope yourself, or use a pair of safety scissors, or carefully hold the helper's wrist when s/he cuts the rope. Always figure out what could go wrong, then think of ways to keep mistakes from happening.

What did the cut magician do? He went off stage, got a cloth, and wrapped his finger up. It got a laugh, and everyone thought it was part of the show.



# Card Spelling

Before starting this trick, take the cards out of the deck that you see in the picture, and arrange them in order like the picture. Put the rest of the deck away.

It doesn't matter which suits are used (hearts, clubs, spades, diamonds). Don't let anybody watch you arrange the cards.



When you're done, turn the stack of cards (the packet) over in your hand and hold it just like normal.

Start with the top card (the 3), and spell the first card in the list (ACE), taking the card off the top for each letter, and putting that card on the bottom. Turn the next card over, and it will be the ace.

Place the ace on the table.

Now spell out the next card in the list, the TWO, putting each card on the bottom like before. Turn over the top card, and place it on the table. It will be the two. Continue with the rest of the packet. The list of cards to spell are:

**ACE**  
**TWO**  
**THREE**  
**FOUR**  
**FIVE**  
**SIX**  
**SEVEN**  
**EIGHT**  
**NINE**  
**TEN**  
**JACK**  
**QUEEN**  
**KING.**

To make this more entertaining, pretend you're not sure if it will work. Of course, you know by now it will work IF YOU PRACTICE!!



# Keep Your Eye on the Card

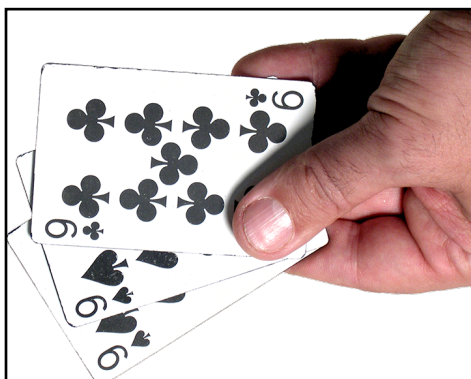

The magician (you) shows three cards. They can be all the same or all different.

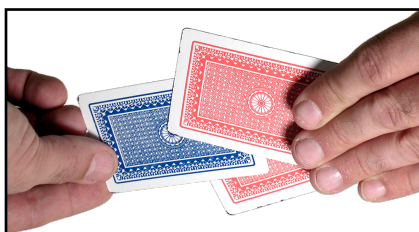

Turn the 3 cards over, and pull out the middle one. Point out that it has a different color back.

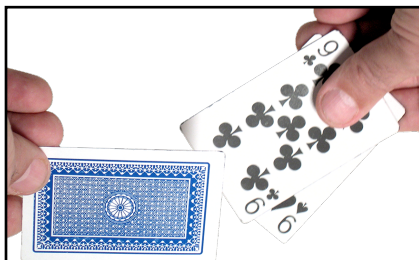

Now turn over the 2 cards left in your hand, showing they are the same cards seen earlier. Pause, say the magic words, and turn over the single card... it's now changed into a different card!



## How this works:

For this trick you need 4 cards. One of them will be cut, so make sure it's from an old deck. Ask permission first!

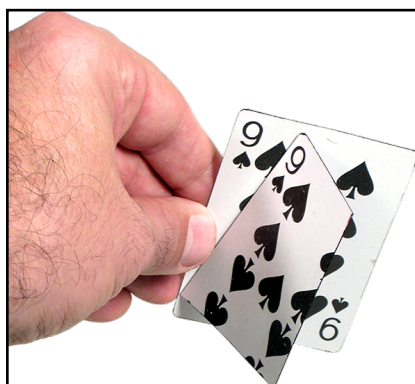

In this photo above, you see how the card is cut. That's the "flap" card. Tape it to the front of another card like shown. Place the tape under the flap, so it's hidden. Make sure the flap does not stick out over the edge of the card it's taped to.

Another card, different from the flap, is placed underneath the flap so the edges line up perfectly. This is important... make sure the edges are exactly even.



Place the remaining card over the flap and arrange it to look like you're simply holding 3 cards in your hand as in the photo below.

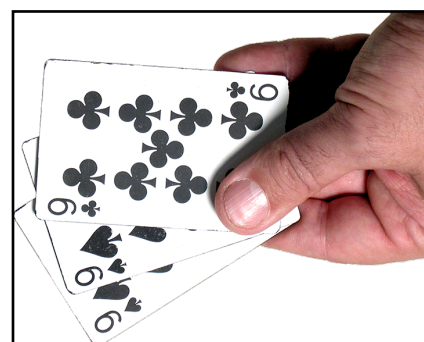

Make sure the cards are turned over before you pull out the middle one.

Slide the 2 remaining cards together a bit to hide the flap before turning them back over. It should look like two cards.

The flap card can be the same color or a different color than the rest of the cards. It depends on the storyline, or "patter" that you want to use when presenting this trick. For instance, the middle card starts out a different color than the other two, then it changes into the same color.

The middle card might be a joker, the other two a 3 and a 5. The joker then turns into an 8 card....  $3+5=8$ . This is a fun way to teach math to a younger brother or sister!

You could even use picture cards that you have drawn yourself. Perhaps photos cut from old magazines could be glued to the cards you are using for a real one-of-a-kind trick.

Practice this often and in front of a mirror. This must be practiced a lot!

# Hand Shadows on the Wall

The art of hand shadows, a form of puppetry, goes back many many years. Perhaps even to the time of cavemen sitting around a fire.

Today, however, you can use an electric light shining on a wall. By adjusting your hands in the shapes of the pictures, and holding them in front of the light, you can make shadows that seem to come alive.

This can be a fun way to tell stories, perhaps as part of a magic trick itself.

These figures will take a lot of practice, although you won't need a mirror for obvious reasons. A video recorder will come in handy though.

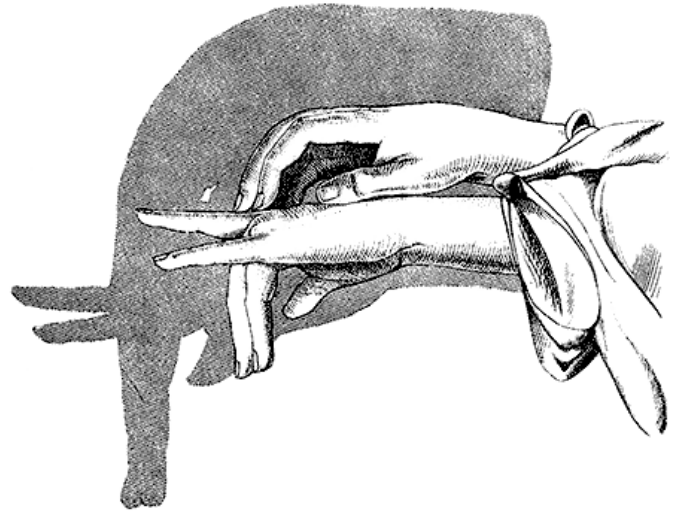



## Helpful Hints... World of Entertainment

Most tricks that magicians perform have been done many times before by other magicians, but rearranged and combined in different ways. What makes one magic show different from another is how the tricks are presented to the audience, along with the personality of the magician.

To be a good magician, you must ENTERTAIN your audience. People will watch a trick and wonder how it was done. But when people are entertained by magic, they don't worry about how the tricks work. They are too busy having a good time.

How do you entertain? Watch other performers, and not always other magicians. Watch singers, comedians, dancers, and see how they use their personality to set themselves apart from the others. The best advice: BE YOURSELF!



# Candy on a Rope

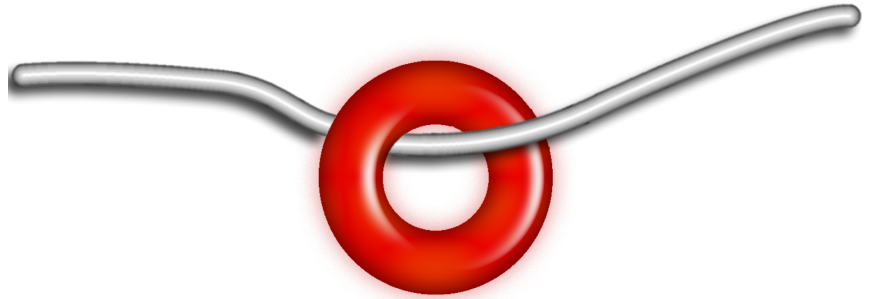

For this trick you will need a roll of Lifesavers™ (or any candy with a hole in the center), a handkerchief, and a length of string or thin rope.

Here is how the trick looks. The piece of candy is on the string, like the picture shows. A handkerchief is draped over the string, hiding the candy. Both ends of the string are held by other people. The magician reaches under the handkerchief, and takes the candy off the string, seemingly without breaking the candy or the string!

How? Before you start the trick, when nobody is around, carefully break a piece of the candy. You may have to try a few to get a clean break.

Glue the two pieces back together with just a little bit of glue, and give it time to dry. Make sure that this prepared candy is the first one in the roll, so it is the one you put on the string. When you reach under the handkerchief, have an extra piece of candy hidden in your hand. The best way to hide it is not to look at it. People tend to look where you look. Quietly break the candy on the string, and let it fall into your sleeve, or hold it hidden in your hand.

Now bring out the unbroken piece, holding it at your fingertips. Let everyone look at the candy and the string. While they are looking at it, place both your hands in your pockets, dropping the broken pieces in also. It's best to put both your hands in your pockets, because if you put one hand in your pocket, it will look like you're dropping something inside.

[www.JimStottMagic.com](http://www.JimStottMagic.com)



## Helpful Hints... Packs Small, Plays Big

There are many tricks and routines that can be done with small props carried around in your pocket.

That's one of the fun parts about learning magic... you're always ready to show your friends a quick routine that amazes and entertains.

When a magician says something "packs small and plays big", they mean it takes up very little room in their suitcase or pocket, yet it can be a really amazing and fun routine.

What does "play big" mean? There was a famous entertainer who did a great show with just a white glove on his left hand. That glove, with the addition of a couple of cardboard ears, became one of the most beloved rabbit puppets of all time. It's the performer that makes all the difference. In this case, Jay Marshall used his ventriloquist skills to bring "Lefty" to life.

A single piece of rope is a common item for magic routines. There are many wonderful routines that can be performed... cut & restored, knots appearing and disappearing, changing color, stretching, escapes. The magician Mac King does a great show with a piece of rope.

# The Appearing Knot on the Rope Trick

You hold a piece of rope so your friends can see both ends.

Drop the end of the rope, while still holding onto the other end. Point to the end hanging down, take a bow, then look at the rope.



Oops... Nothing has happened.

Try it again, but still... nothing happens.

Then remember that your friends get to help by saying the magic word. When they do, you drop the end of the rope and there is a large knot tied on it. Thank your friends for being such good magicians.



### Here's the secret:

Before you start the trick, when nobody is looking, tie a bundle of knots near one end of the rope. Leave an inch or two sticking out.

This prepared rope can be kept in your pocket, backpack, lunch-box, book-bag, anywhere you can reach it easily and it stays out of sight.



When you're ready to start the trick, hide the knot in your fingers like the photo to the left. Wrap them around the rope so the knot doesn't show.

Your hand should look relaxed. If you're having trouble hiding the knot, make it smaller so it fits in your fingers better.

The first two times you do the trick, drop the end held between your fingertip and thumb. Keep the knot hidden.

Pretend like you messed up. This is a good chance to practice your acting skills. You want the audience to think you made a mistake.

On the third try, remember that it works if the audience says the magic words. When they do, you appear to do the same move as before. But you actually do it in reverse. Hold the end firmly between your fingertip and thumb, then open your other fingers to let the knot end fall down.

Point to the knot, and pause. This pause is important, because it tells the audience that something has just happened, and it gives them time to notice the knot has appeared.

This trick can be done with something tied to the rope instead of a knot (as long as it will fit into your hand). For example, you could have a ring appear, or a small toy.

This is a fun trick that can be done just about anytime. You can carry it with you everywhere, so you're always ready to amaze & entertain your friends!

# Ring On & Off The Rope

A solid bracelet is tied onto the string. Both ends are held by someone, then a handkerchief is draped over top of the bracelet. You reach under the cloth, and pull the bracelet off the string, as if by magic!

Step 1: The secret is the way you tie the string onto the bracelet. Fold the shoelace in half, then pull it through the bracelet, as shown in figure 1.

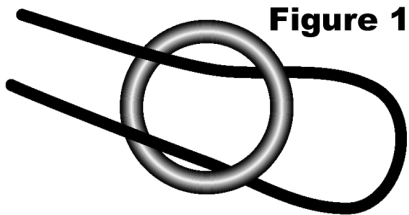

Step 2: Pull the ends through the loop at the middle of the string (see figure 2), and pull it tight. This is how the ring is tied to the string.

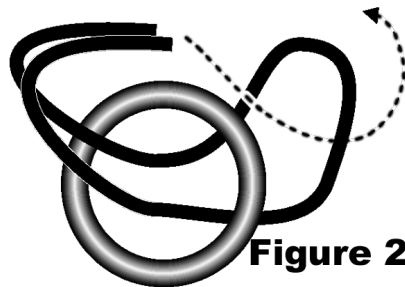

Step 3: Have somebody pull the string, to make sure it is tight. Figure 3 shows what it looks like. Don't jerk on the string, or the bracelet may break.

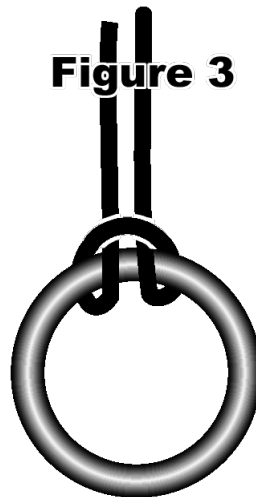

Step 4: Have a friend hold both ends of the string loosely. Drape the handkerchief over the bracelet, making sure it can't be seen. Reach under the cloth, and pull the loop of string over top of the ring.

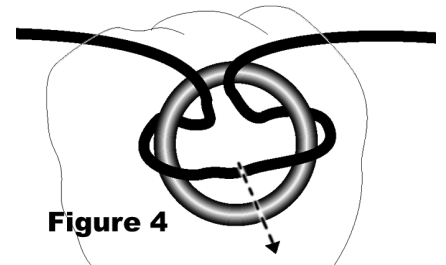

Pull the bracelet off the string, lift the scarf, and show it to your friends. Let them look at the bracelet, handkerchief, and string.

You can also do this trick in reverse: Have a friend hold both ends of the rope, then you cover the center with a scarf. Hold the bracelet under the scarf, and "tie" it onto the rope while the ends are being held. Lift the scarf to finish the trick.

# The Shoelace Insta-knot

## Helpful Hints... What Else Could It be?

Here is a fun game that can help you become a better entertainer and help you to think faster! You can play it with as many people you want, or even by yourself.

Hold up an object, the simpler the better. A piece of rope is a great thing to start with.

Ask somebody what it is. When they say what it is, you say... "Yes, what else could it be?" to somebody else in the game.

If you want to give an example, you could start by holding up the rope and saying "This is not a rope, it's a piece of hair from a giant... what else could it be?"

Write the list on a notepad as they are being said. If it's a large group, have a few people writing them down.

This is a type of game called brainstorming. When you want a new idea, this and many other techniques can help.

Once you've made a list of objects describing the rope-thats-not-a-rope, make a list of answers to the question.... "Why did it end up in a knot?"

Other lists could be made:

- *What is it after it's tied?* (bow-tie, hair bow, eyeglasses, etc)
- *Where is the object located?* (A strand of spaghetti may be inside a restaurant).
- *If the object talked, what would it sound like?* (a snake may use hissing noises when talking).

*This is what the audience sees:*

The magician holds a length of rope (or shoestring, ribbon, yarn) in his/her hands.

With a smooth movement, the hands are brought together, touch then separated. As the hands are moving apart, it's seen that a shoelace knot has appeared on the rope.

**Here is the secret:**



This sleight of hand move is a fun skill to show off to your friends and family, after you have practiced thoroughly. You'll need a piece of rope. Shoelace, yarn, ribbon or thick flexible string will also work, but not thread or curly ribbons.

Start by holding the rope in your hands like you see in the top picture. Relax your arms. Make sure you're using the correct hand. The right hand holds it loosely like a hook, the left hand holds it palm up. Notice the amount of rope hanging down on the sides and in between the hands are about the same size.



Turn both wrists so the hands are now in this position. These photos are from the magician's point-of-view.



The first finger of each hand is raised up a bit so it looks like a lobster claw. Notice the left hand is closer. The thumbs are not used, so keep them out of the way.



Now use those lobster claws.

Grab the rope with your fingers (squeeze tight) like you see in the photo. Keep your fingers as

flat as you can, and don't use your thumbs.

Keep gripping the rope as you pull your hands apart. Don't try to do it fast,

do it smoothly. Now you have a shoelace knot!

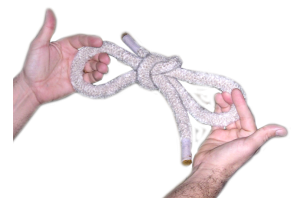

# Cut & Restored Rope

## Helpful Hints... Types of Illusions

- **Vanish.** This is when something disappears.
- **Production.** Something appears from nothing.
- **Transpose.** An object magically moves from one place to another. This is actually a vanish and production combined.
- **Change.** An object could change color, shape, size, even change temperature.
- **Levitate.** Something floats in the air, without any visible means of support.
- **Torn & Restored.** Something is cut or destroyed, then brought back to normal. The cut & restored rope is this type of illusion.
- **Mind Magic.** Reading a persons mind, or predicting what they will say or do in the future.
- **Animate.** Bringing something to life, such as a puppet. This can also be a type of mind magic, such as moving an object by thinking about it.
- **Penetrate.** When an object goes through another object without harming either one. Sawing a person in half is this type of illusion... or is it a "torn & restored"?

This is a classic of magic. There are hundreds of ways to do it. If you study magic long enough, you'll discover that every magician has a favorite method.

The envelope pictured has a notch cut on each end. This is for the rope to go through. These notches may be cut while the audience is watching. The holes on the front are cut before you start the trick, and should NEVER be seen by the audience. The holes are NOT cut all the way through the envelope, but just one side.

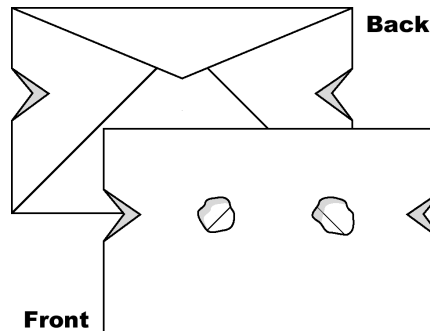

Pull the rope through the envelope, but when threading the rope, slip it out and back through the hidden holes. Practice this so it's done smoothly, without the audience being aware of it. Make sure the audience does not see this!

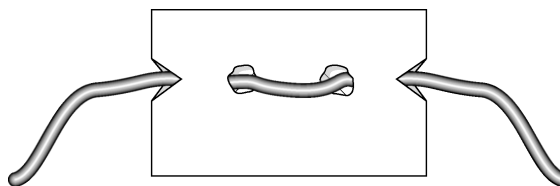

Lick the envelope, then seal it. For a joke, pretend the glue tastes bad, and make a funny face. Don't cut your tongue.

Now fold the envelope in half, and tighten the rope by pulling the ends. Not too much, don't tear the envelope.

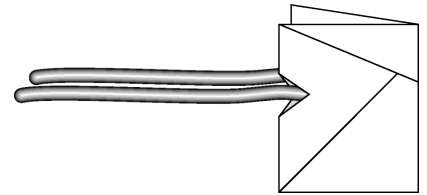

Carefully cut along the fold. It will look like you also cut the rope. Put the ends of the envelope back together, wave the wand, say the magic words, wiggle your ears, or whatever, then yank the rope out (tearing the envelope) and show it's restored!

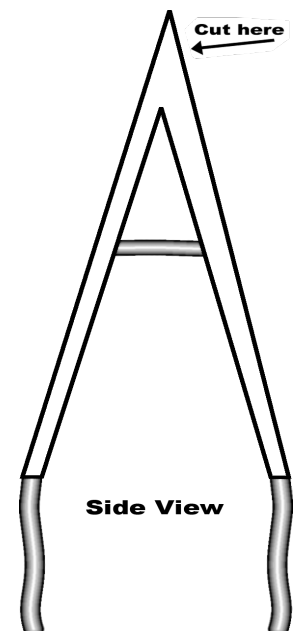

Side View

# Juggling 101

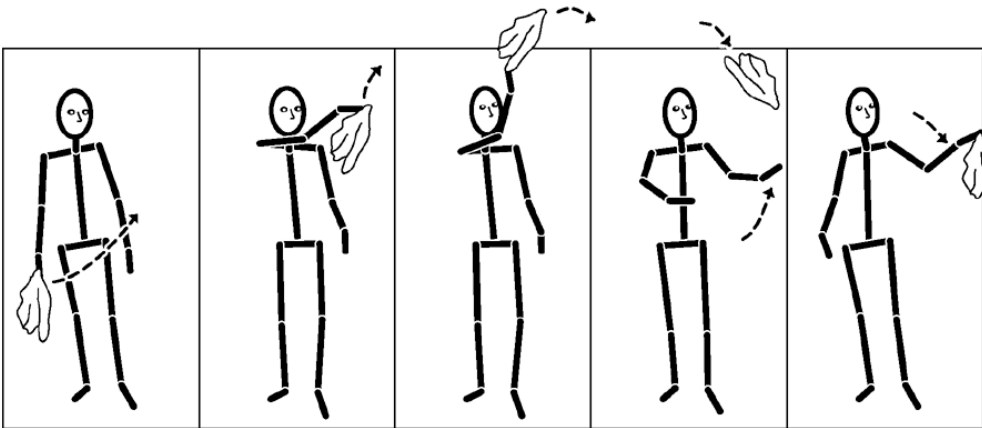

Juggling is easier than most people think... start with one and work your way up to three. It will take practice and patience. Learn each step very well before moving on to the next one. Keep working at it, and you'll get it!

Three lightweight cloths are best to use. They fall slowly and are easy to catch. That way you can concentrate on learning the patterns. If a handkerchief is unavailable, use a plastic grocery bag that's been cut open.

**ONE SCARF** - Hold one scarf dangling from the center. Swing your arm across your body, and toss the scarf up and across.

With your other hand, reach up and catch it. Now toss it across your body to the first hand. Do this over & over & over. If you don't learn this step well, the others will be much harder.

Try to make each toss the same height. Study the drawings and you'll see how it works.

**TWO SCARVES** - Hold one scarf in each hand. Toss one just like before, and when it gets to the top of the arch, toss the other scarf across your body. Catch the first one, then the second.

Don't toss both scarves at the same time. Wait until the first scarf is half-way to your other hand before tossing the second scarf. Remember the two scarf slogan: Toss-Toss-Catch-Catch.

**THREE SCARVES** - Hold two scarves in one hand (Black & White), one in the other (Grey).

Always start by tossing one of the two scarves. While that scarf is in the air, toss the grey scarf from the other hand.

Catch the white scarf, then toss the black scarf so your hand is empty to catch the grey scarf. Always catch with an empty hand. Don't place one scarf into another hand, always toss it across to your other side.

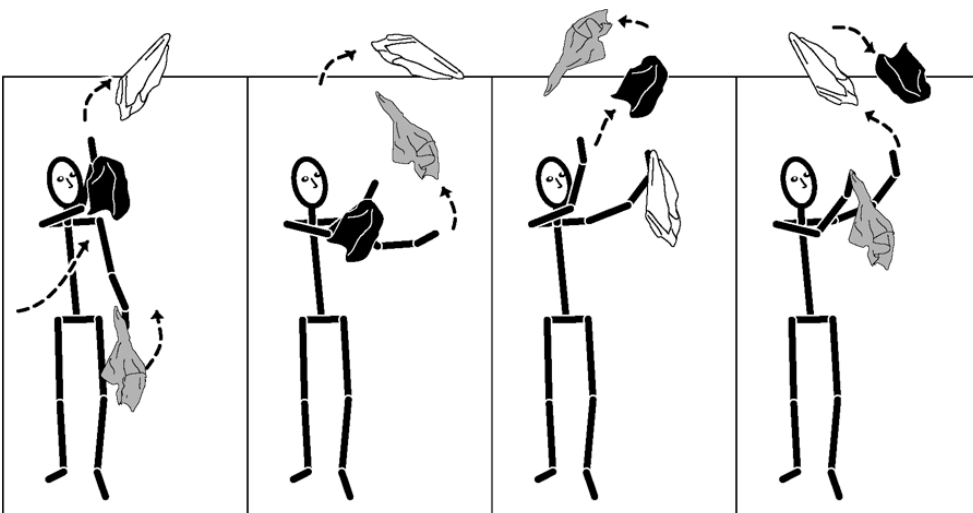
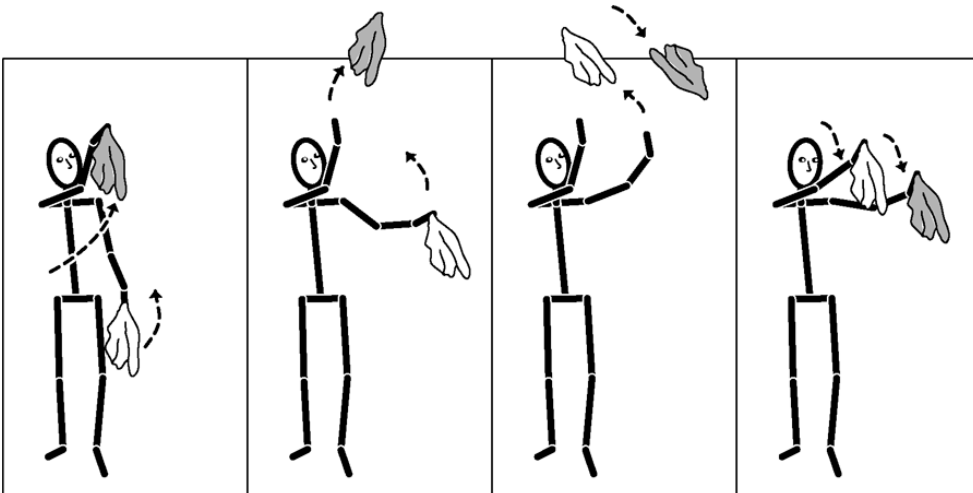



## Helpful Hints... The Pause That Refreshes

A pause can be an important part of your show. One of the most common mistakes beginner magicians make is to rush through their tricks.

Audiences need you to pause at certain times so they can applaud, or so they can see a new prop, or so they can see that the big finish is about to happen.

If the audience likes your show, then they will be glad to applaud. However, if you don't pause, they won't know when to applaud.

When you want to start a new trick, and bring out a strange prop, hold it up so everyone can see it and pause for a short time so everybody can get an idea of what it is, then start your trick.

A well timed pause can make your show look a lot more professional!

# The Rubber Pencil

The rubber pencil is more of an optical illusion than a trick, but it still is fun to include in a magic show, especially if you are already using a pencil for some other trick.

First show the pencil is normal by tapping it on the table, or letting somebody look at it. If you can borrow a pencil, even better.

Hold the pencil between your first finger and thumb tips. Now slowly twist your finger and thumb tips back and forth so the ends of the pencil go up and down. The ends don't need to move very far.

At the same time you are twisting the pencil between your finger and thumb, slowly move your hand up and down about two inches each way, and the pencil will look like it is bending, as though it were made of rubber. Watch yourself do this in front of a mirror, and you'll see how this looks very strange to an audience.



After showing the pencil looks like it is made from rubber, hand it to somebody so they can see it is actually stiff and hard.

This could also be done with a pen, marker, small ruler, even your magic wand.

Here is another way to do this so it looks even stranger. When you are moving the pencil to make it look like rubber, do it in front of a TV that is turned on. Now it looks like you are holding many pencils in your hand, and they are all rubber.

Why do you think it looks like that?



# Color Changing Pencil

After wrapping a pencil in a napkin (or handkerchief, paper towel, etc), the audience says the magic words. When the pencil is unwrapped, it has changed color!

## Helpful Hints... Variations on a Theme

Changing the color of a pencil is a great trick, but there is so much more you can do with this technique. The basic idea is that one object is switched for another, without the audience being aware of a switch.

Does it have to be done with a pencil? Of course not. You could turn a fork into a spoon. This is a perfect trick to perform at a fancy restaurant with cloth napkins. Since you're sitting down, it's easy to slide the hidden item into your lap when you're done.

A pencil could be turned into a crayon. A short stick into a toy snake. A chain with tiny links into one with large links. A piece of yarn becomes a ribbon. Turn a \$1 bill into a \$10 bill... You get the idea.

Instead of a napkin, you could use a towel. What goes with a towel? How about turning some dental floss into a toothbrush.

Whatever you use in place of the napkin, remember that it must look the same on both sides.

Magician sits or stands on this side of the napkin.

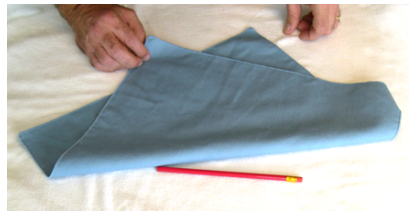

Spread the napkin flat on the table, corner pointing to you (pretend that's home plate on a baseball diamond). Place the pencil in the middle so it's pointing towards 1st base & 3rd base. Point out that it's a yellow pencil (or whatever color yours is).

Unknown to the audience is an extra pencil hidden under the napkin. Same position, different color. Make sure nobody sees this. Wrinkle the napkin a little to hide its shape underneath.

Grab both pencils and the napkin together, and start wrapping. It should look like you're wrapping just one pencil (the top one)

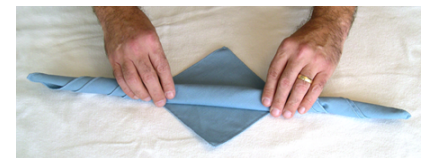

When you get to this point, with just the corners showing, turn the napkin over. Do this casually so it looks like you're still wrapping the napkin.



Wave your wand and ask the audience to say the magic words. While they're doing that, slowly pull the corners apart and show that pencil has changed color!



# Appearing Pencil



The audience sees your empty hand holding a handkerchief (or a cloth napkin, paper towel, etc)

Tell your audience to watch closely. Never tell them you will make a pencil appear... that would spoil the surprise of the trick.

Gently clap your hands together, slowly lift the cloth, and suddenly a pencil appears! This is a big surprise to the audience, and is actually easy to do. Of course, you still have to practice to make sure you can do it well each time.



**Here's the secret:** Before starting the trick, when nobody is looking, hold a pencil in your hand like this.

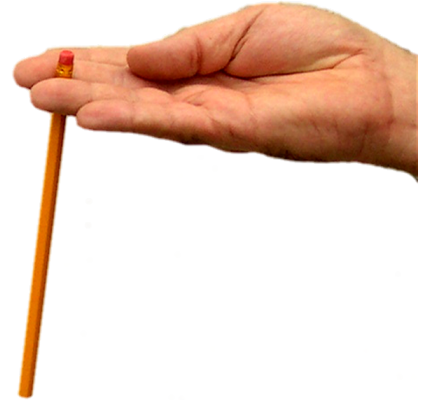

Notice how the eraser end is up, and sticking out above your fingers just a little bit. This is so you can grab it later.

Now drape the napkin over your hand, and position it so the corner is pointing towards your wrist, like in the first picture. Make sure the pencil is held at your finger tips. This way it's hidden much better by the napkin. Keep your hand flat, and your thumb holding the cloth.

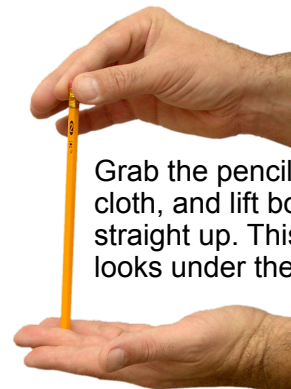

Grab the pencil thru the cloth, and lift both straight up. This is how it looks under the napkin

Turn your wrist to hold the pencil in a normal position (like the picture to the left). Whisk away the cloth and reveal the magically produced pencil!

# The Rising Pencil Routine



Dropping a pencil into an empty plastic water bottle may seem a bit odd. Waving your hand over top and saying magic words might be even stranger. But when the pencil begins moving and floating by itself, you're magical!

The other end of the thread is tied to a button on your shirt, or your belt buckle. It needs to be long enough that you can hold the bottle, with the pencil inside, about a foot in front of you before the thread gets pulled tight.

By moving the hand holding the bottle away from your body slowly, the pencil will be pulled up. Start by having the pencil move just a little, then a bit more, then rising slowly. Act surprised when it's floating.

## How does it work?

The pencil has a length of thread tied to one end. These photos show a thick string, but that's only so you can see it on the page. When performing this trick for an audience, use a thin thread. Also make sure it matches the color of your shirt as closely as possible. Experiment with various colors and you'll see which work best.

Drop the pencil in the bottle, with the threaded end at the bottom.

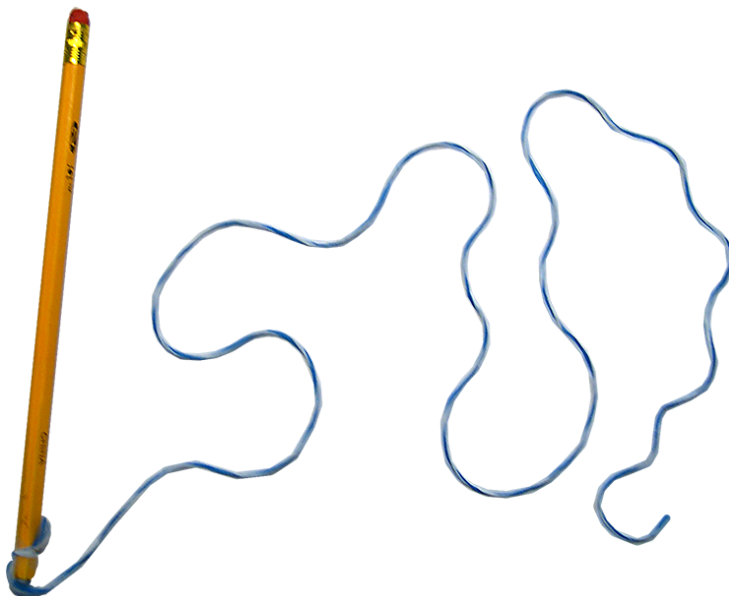

This is a very fun trick to do, but it must be done carefully. Moving the bottle away from you should be performed smoothly and slowly. Use your body positions, hand, and eyes to keep people looking at the pencil.

Of course, this trick could be done with something other than a pencil. You could make a wand rise from the bottle, or have the wand rise from a skinny vase.



Combining two different types of illusion in this trick can turn it into a very interesting routine. At first, the pencil or wand is becoming animated. It moves around on it's own, as if it's alive. You could use the movements to illustrate a short story, or even use the pencil as a puppet who won't stop moving around.

Later in the routine, the pencil or wand levitates (floats)... a whole new trick in the minds of the audience!

As with all tricks, practice this one often and in front of a mirror.



## What other ways are there to make the pencil float?

This is a fun and easy way to make a pencil float, and it can also be used for lots of other objects. However, it's not the only way. Making things float has been in the repertoire of magicians for hundreds of years. It's one of the most mystifying illusions of all.

But how? In the case of The Magnetic Floating Pencil of the Universe trick, your finger provides the lift. But wouldn't it be more amazing if you could let go of your wrist and still have the pencil stay in place!

If you have an extra pencil, wear a wristwatch and long sleeves, you can make it happen. Slip the extra pencil under your wristband (when nobody is looking, of course) and hide it under your sleeve. When you are holding your wrist, secretly slide the hidden pencil out until it's holding the pencil in your hand. Make sure the other end is still securely under your watchband. Now do the trick as before, with your hand holding your wrist while you slowly open the fingers to show the pencil floating. After a short pause, you can then let go of your wrist completely!

# The Magnetic Floating Pencil of the Universe

Holding a pencil in your fist, you explain that it has amazing properties. If you hold your arm really stiff, and don't move, the pencil will become magnetic and stick to your hand.

Grab your wrist with the other hand to steady your arm, and stare straight at the pencil held in your fist. Slowly open one finger at a time, until just your thumb is left holding the pencil.

Pause for dramatic effect, then lift up your thumb to reveal the pencil sticking to your hand like a magnet!

**The Secret:** As you can see in the picture, your other hand is doing more than just keeping your arm steady. It's also holding the pencil.

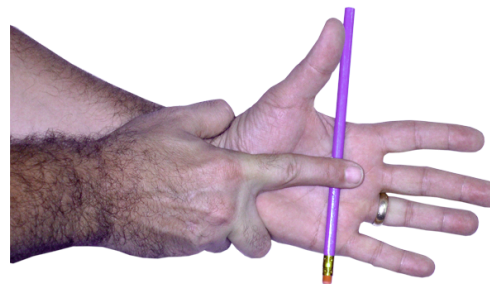

Of course, make sure the audience does not see this part of your hand. Position yourself so the side of your body is towards them.

When you grab your wrist, your first finger straightens out and holds the pencil in place.

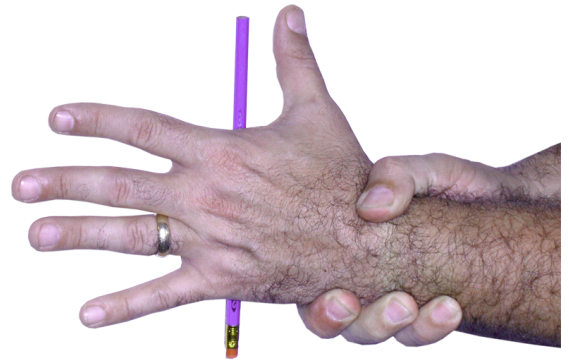

This should be done without anybody noticing. When you're practicing this trick, your goal is to grab your wrist and hold the pencil in one movement, so there are no suspicious adjustments or wiggling.

The rest is acting, and making it interesting to your audience. You can pretend like it is really hard to do, and you have to concentrate very hard.

This same trick can be done with other things besides a pencil. If you have a magic wand, this is a great trick to include. You could also use a spoon, a stick, a straw, almost anything that will stick out of the top & bottom of your hand when held in a fist.

# Optical Illusionary Tricks

The eyes cannot be fooled. It's the brain that is fooled. When something is seen by your eyes, it's your brain that figures out what it is. There are many techniques the brain uses, and there are also many ways to trick your brain. Check out these pictures.

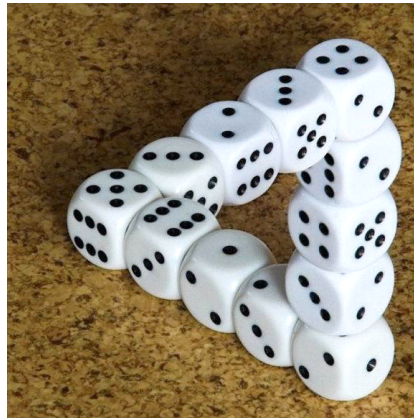

Looking at these dice can be very confusing!

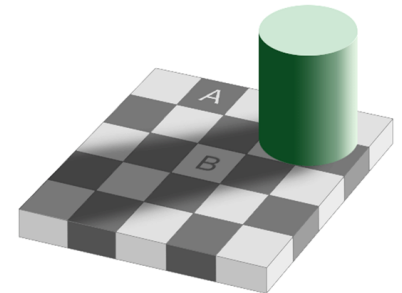

Believe it or not, the squares marked A & B are exactly the same color. Really, they are!

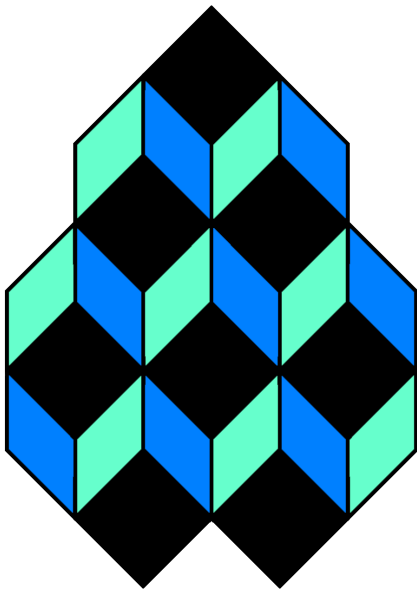

Do you see 6 or 7 boxes?

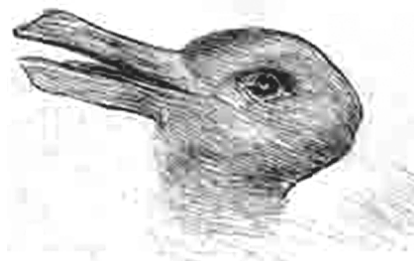

Is this a rabbit looking to the right, or a duck looking to the left?

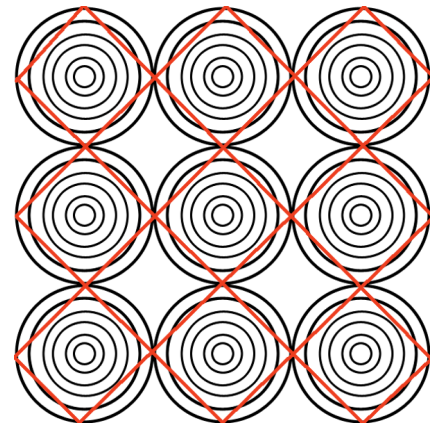

Those red lines are actually straight.

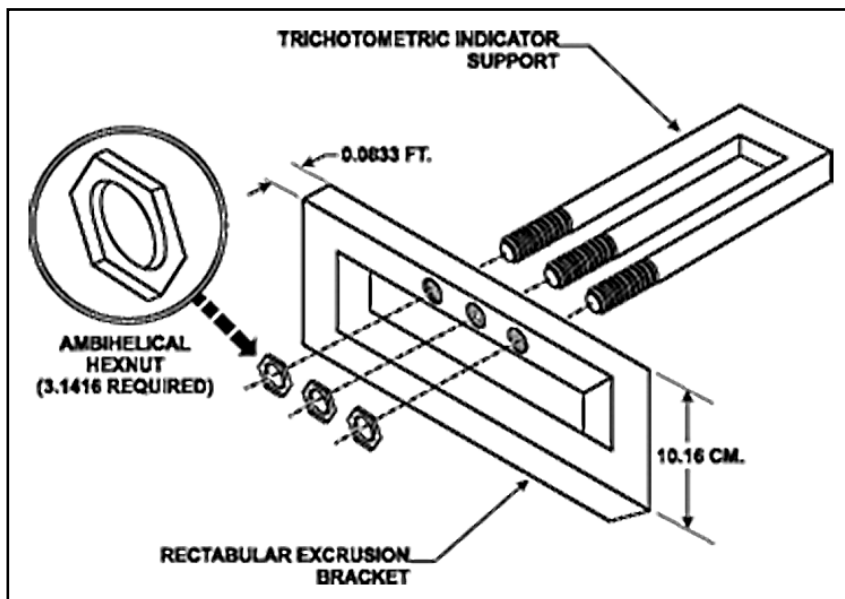

Do any of these parts make sense?

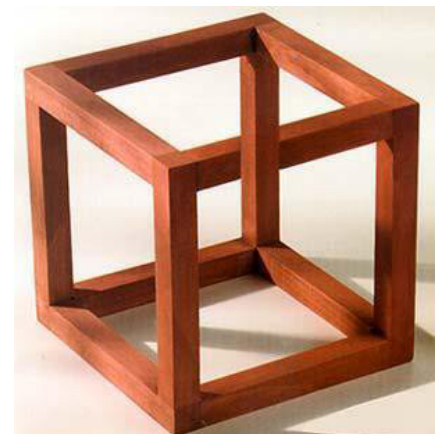

Maybe there are alternate dimensions.



## Helpful Hints... Comedy in Magic

When you do a magic show, there are many ways to present it. How you present it makes a big difference on how your show is seen by the audience.

You could be very serious. This works well if you are doing a mind reading trick, or a major illusion (such as vanishing the Statue of Liberty).

You could be very friendly. It's always good to be friendly, but especially if you're doing a show for friends or small children.

You could be funny. The comedy approach is the most popular. There are different types of comedy. At one extreme is a slapstick clown, who keeps falling and tripping, to a nightclub comic, who tells jokes and does impressions.

The best way for deciding which presentation to use is to be yourself, and do what feels right for you.

# Comedy Trick Cards

If you've ever seen a magician on TV, you probably know what this next flourish looks like. (A flourish is not a trick, but something that just looks flashy). A deck of cards is "sprung" from one hand to another, like a waterfall.

Most of the magicians you've seen use real sleight of hand, called "springing the cards". It takes time to learn, but it's not very difficult. You hold the deck in your hand, at the fingertips, and bend it inward toward your palm. Let the cards slide off the fingertips, holding them back at the thumb tips. Catch them by holding your other hand as though you were holding a baseball. Aim the cards towards your fingers. It takes practice... ideally over a table or bed to make it easier to pick up the cards that scatter.

The method on this page is easier, and you can use it to get a laugh in your routine.

As the photo shows, a few cards from the deck (about 40) are stapled together at the ends, so it zig-zags. Make sure you use an old deck, because stapling the cards will mean you can't use them for anything else.



Position your hands one on top of the other. Hold the trick deck in the top hand, and slowly let them drop into the bottom hand, one at a time. Even though you're not using sleight of hand, it still requires PRACTICE! As you get better, move your hands farther apart.

Here's how to get a good laugh using these cards. After the second time of dropping the cards from top to bottom, forget to catch them with the bottom hand. Let the cards hang free. Don't notice at first, pause, then see the cards and react. Pretend you've messed up the trick, and act as though you are embarrassed.



## Helpful Hints... Gag Lines

Whether you are doing tricks for friends, or performing shows for a room full of strangers, it's important to make the tricks entertaining. One way is to have some funny things to say. These are called "ad-libs", because they are supposed to sound like you just made them up.

Even the best performers have jokes and funny "lines" written ahead of time. Whenever you hear something funny, or think of a good line, write it down in a notebook. Here are a few to get you started:

- "Notice that my fingers never leave my hand."
- "Please close your eyes, because the trick is a lot easier to do that way."
- "My first trick this evening is impossible, so I'll start with the second"
- (Take the top card from the deck, place it in your friends hand, and say) "Select any card you like from the deck"

# Comedy Magic Marker

This is more of a joke than a trick, but to make it really funny, you need to act like it is an amazing magic trick.

Start by borrowing a marker from somebody, then tell the audience that you can turn this into a magic pencil. If nobody has a marker, just use one of your own.

Place the marker on the table, wave your magic wand, say the magic words, wiggle your toes, or whatever, then say that this marker is now a magic marker and will write whatever color they name.

Have somebody name any color. Let's say it is red. Now pick up the marker, and get ready to write. Make it seem like you're getting ready for a great feat of magic.

When you have everyone's attention, quickly write the word RED on the paper in big letters, and hold it up for all to see. You may now hand out the marker and the paper for examination.

Here is another good trick that turns out to be joke. Tell a helper you have written a prediction of what they will say. Show the back of the paper, but make sure nobody can see through it.

Now ask if your helper knows what is written on this paper. When s/he says no, you turn the paper around and show the word NO in big letters.

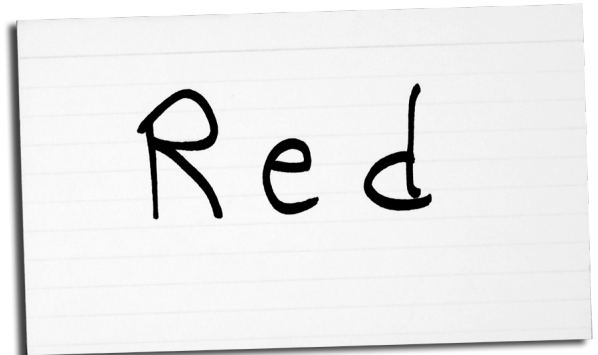

# Silly Balloon-in-Bag Trick

Tricks with balloons are always fun for audiences, especially children. They are bright and colorful, bouncy, and take up a lot of space. Children will usually remember a fun game they've played with balloons when they see one.

This balloon trick is a silly little routine, perfect if your magician character wears a red nose and does comedy magic.

## Here is what the audience sees:

On a table, or in your hand, is a brown paper grocery bag. It's fine if the bag is a bit torn and wrinkled.

Open the bag, turn it upside down, and an inflated red balloon falls out. Watch as it falls, and bounce your head up and down as the balloon bounces. This will look very funny.

Place the bag on the table, open side up.

Untie the balloon, and let the air out. It will make a silly noise, so make sure to react to that. You could point to the balloon and say in a stern voice... "I heard that, now say excuse me".



Hold the empty balloon up for everybody to see, and drop it into the bag.

Now comes another silly part of this trick.... lean over the bag, and blow into the top. Blow hard, as if you were actually blowing up a balloon. Keep your head above the bag. Stop now & then to catch your breath.

Blowing up a balloon is hard work!

When you are done blowing, look into the bag, pause, then look at the audience and smile again.

Pause again, then reach into the bag and pull out an inflated balloon. Hold it up for everybody to see, and take a bow!

Here is how this is done:

You actually have two red balloons in the bag at the beginning of this

trick. Of course, they could be any color, just make sure that both balloons are the same color and the same size.

One balloon is kept in the bag with a little bit of tape. Or you could just hold the balloon in place with your hands when you turn the bag upside-down.



However you do it, make sure that only one balloon falls out of the bag when you turn it upside down. Also make sure the audience does not see inside the bag when you turn it. Keep the open part pointed towards you when you turn the bag over.

The balloon that falls out should be loosely tied so you can easily untie it and let the air out.

Another idea is to have an uninflated balloon fall out of the bag at the beginning. You blow it up, let the air out and then drop it into the bag.

The rest of this silly routine is just acting goofy and having fun!

On the outside of the bag you could write your magician name, or you could write "The World Famous Balloon Trick".

# Global Humor

## Helpful Hints... Palm Reading

Tell your friends you can read their palm, then pull a fake rubber hand from your pocket. Look closely and read a story from it, "Once upon a time there was a beautiful princess." (You won't have to read any more than that.)

Ask what is so funny, then turn the hand around so they can see the words, which proves you can read palms.

When you carefully and neatly write the words on the hand, use a marker, and be careful. Ink from the marker can be very messy.

Now tell them that palms are fun to read, but you liked the movie better.

Another joke is to ask your performing partner... "would you like your palm read?" When they say yes, paint their hand with washable red paint, or write the word "RED" in big red letters. Don't do this to a volunteer from the audience unless you've gotten their permission earlier.

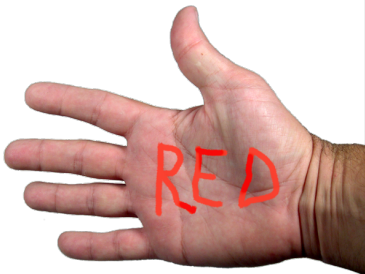

If you can find a small globe, here is a funny gag to use sometime during a show. Small globes can be found at gift shops, and they are often used to save coins and sometime you'll find them with a pencil sharpener inside.

Ask a friend if s/he knows how to get to the nearest store. When they start to give you directions, tell them a map would make it easier, and pull the small globe from your pocket. Point to it, and say "We are here, and the store is there. But don't think you can get me lost, because I know that blue part is water."

Another gag you could use is this. When talking with someone, you might discover that you both know the same person, or you both have the same birthday, some sort of coincidence like that. When that happens, show the globe, saying ... "It's a small world, isn't it!"



Here is my favorite. When someone asks where you live, or you find out where they live, pull out the globe and say "That's easy to get to, it's only an inch and a half drive from here!"

# You're So Funny!

## Funny Comedy Gags

Here are some quick, funny gags that can be put into just about any show, or combined with other gags. These may also be useful as Scout meeting skits, talent shows, classroom assignments, etc.

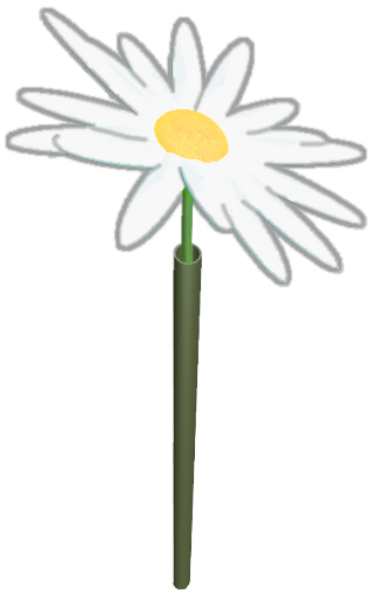

### Have a flower!

As the audience is entering the theater, hand someone a flower. However, the flower stem is not what it seems (see illustration.) By holding the top of the stem, and letting the audience member hold the straw, you walk away with the flower, and they are left with just a straw.

The Flower Stem gag can also be used with a helium balloon on a short string tied close to your finger, and a long length of string held in your hand. The person taking the balloon from you ends up with just the string.

With both these gags, it's a good idea to have a real flower, balloon or some other treat to offer after the gag, so they don't feel cheated

## Dusty, dusty, dusty!

This is a classic warm-up, used by many famous entertainers throughout history. It's really quite simple, but tons-o-fun! Merely walk through the audience with a feather duster, apologizing for the dusty seats. Just as somebody is about to sit, gently dust off their seat, but get carried away, and start gently dusting off the person's head, hands, jacket, armpit, etc.

## Funny Handshakes

This was made famous by the Marx Brothers. Whenever two clowns meet, they hold out their hands as though to shake hands, then lift their legs up into the others hand and shake each other's ankles. Many other variations could be developed... use your imagination!

## The Highly Trained Flea

Performer in animal trainer costume offers to show his/her performing partner a trained flea for only five dollars, which is paid. The partner is asked to hold the flea's jacket, boots, and hat, which he does. Now the flea does many amazing tricks, such as jumping from one hand to the other, doing back flips, etc. There is actually no flea, only the animal trainer using his eyes and head "watching" how the flea is moving (pantomime).

When the flea is finished, the animal trainer applauds, then slowly realizes that he just squashed the flea. He starts crying and acting very sad. The partner is not upset in the least and he says he never believed there was a flea in the first place. The animal trainer pauses, and asks "Then why are you holding the flea's clothing?" The partner gets angry, throws the flea's clothes down on the floor, and stomps off. The animal trainer smiles, then takes a big wad of five dollar bills from his pocket and counts all his money as he walks away.

## Comedy First Aid

At some point a performer pretends to get hurt, and two other people come on with a stretcher to take him away. However, the stretcher is just two broom sticks with a blanket laid on top of them. Lay stretcher down, roll patient onto stretcher, then pick up stretcher and walk off. The gag is, the blanket from the stretcher, and the patient, stay on the ground while the two people walk off with just the poles.

This is very funny with ambulance driver type jackets, siren sound effects, flashing lights, and frantic, hurried movements. You might even find hats with battery powered sirens on top. Very funny!

## Running Gag

A running gag is done throughout the show. Usually the first part near the beginning, the second in the middle, and the third near the end.

1: Performer walks onstage with a case of soft-drinks (empty cans in cardboard box.) Another person (show MC, scoutmaster, teacher) says... "Where are you going with those?" Performer replies "I'm taking my case to court."

2: Performer walks on again with a case of soda and a small ladder. The other person asks "Where are you going now?" The performer replies... "I'm taking my case to a higher court."

3: The performer enters with empty cardboard box. The person asks "What now?" Performer replies "I lost the case."

# Where Did the Square Go?

Here is a trick that's actually more of a puzzle. Be warned, however, that you're on your own to figure it out! Trace or make a copy of the large picture below, and cut along the dark lines so you have 5 separate shapes.

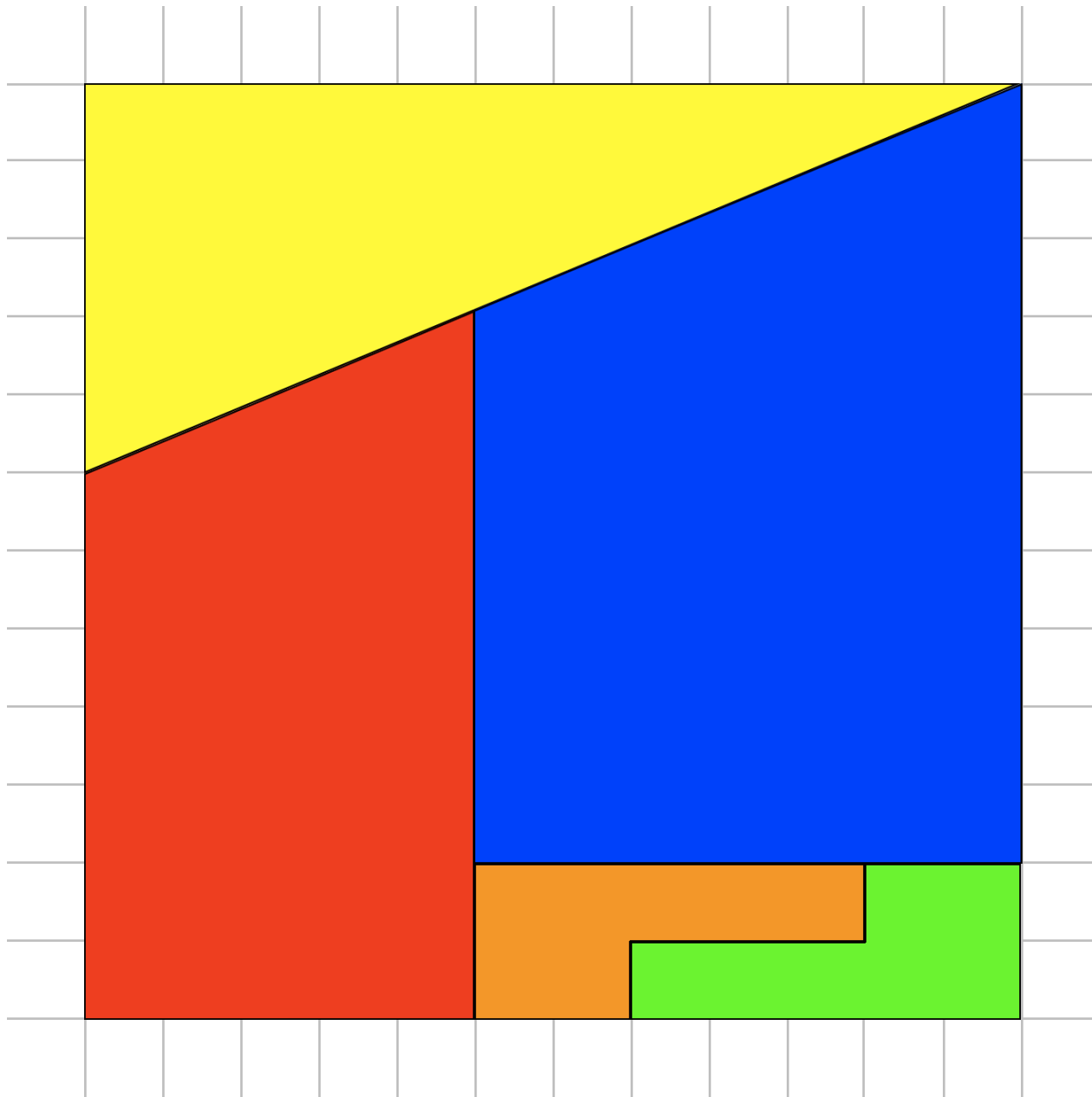

Re-arrange the shapes so it looks like this:  
See the missing square in the lower right hand corner...  
Where did it go?

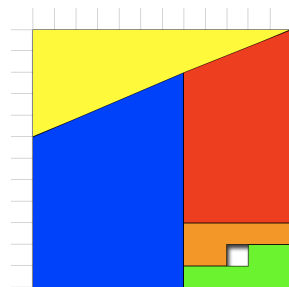

# The Crayon Trick

## Helpful Hints... Costumes

The kind of clothing you wear when you perform is important. If you do a funny act, then you might want to get some old clothes that are too big for you. A hat is also a good thing to have. A jacket is handy, especially if it has a lot of big pockets that you can carry tricks inside.

Of course, you don't have to wear goofy looking clothes to do a comedy act. Some magicians do very funny shows wearing a nice suit and tie.

For a serious act, you'll want to look your best, with a nice suit, well combed hair, and a tie.

Costume clothes can be found at many secondhand stores. They are low priced, and there's plenty to choose from. Also keep an eye out for hats, ties, even suitcases when you are there.



Who wouldn't love to see inside a closed box, especially around birthday time. This trick will make people wonder if you really can.

A spectator places any color of crayon into a box held behind your back. You can tell, without looking, what color is in the box.

Dump all the crayons to be used on the table. Now hold the empty box behind your back, and turn around. Instruct someone to place one crayon in the box. When they're done, turn around to face them, and pretend to concentrate, staring into their eyes.

What you're actually doing is scraping a bit of crayon off with your thumbnail. Bring your hand in front of you, and point to the audience. When you do, glance at your thumbnail to see what color the crayon is.

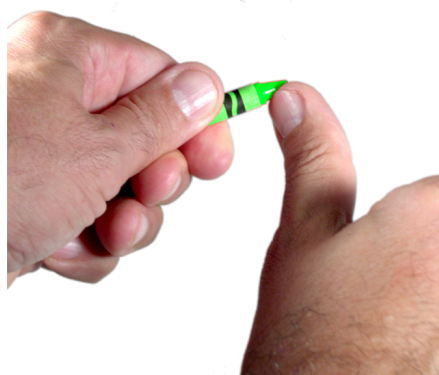

Try not to move your eyes though, because people will notice that. Instead, look at the audience, and move your thumbnail up towards your forehead. This will give you plenty of chance to see the crayon's color without everybody noticing your eye movement.

Announce in a loud clear voice what color s/he placed in the box, then place the closed box on the table and let everyone open it and look inside.

# Cardboard Card Prediction

On the table is a piece of cardboard and a deck of cards. You explain to the audience that you will do this trick without touching the cards at any time.



Pick up the cardboard and have an audience helper pick up the deck of cards. Instruct them to place a card on the cardboard. You slide it off and begin making a pile of cards.

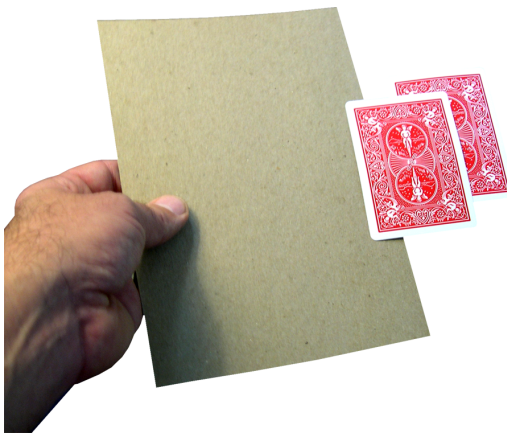

Have another card placed on the cardboard, then another and another. While the pile of cards is forming, tell them they can stop at any time, they can pull a card from the middle of the deck, they can even cut or shuffle the cards if they want.

When they decide to stop, you drop the cardboard on top of the pile of cards. Move your hands away, and ask somebody to please turn over the piece of cardboard. Written on the other side is a prediction. Now have somebody turn over the top card of the pile, and it is the same card!



## How does this work?

The reason your audience helper can cut, shuffle and use any card in the deck is because the predicted card is not in the deck at all.

The whole time you're holding the cardboard and placing the cards on the pile, the 2 of hearts is held underneath the cardboard, hidden from view. When your helper is finished laying down the cards, you drop the cardboard on top of the pile. This places the predicted card on top. That's it! Just make sure the card is positioned the same way as the pile of cards.

There are a few details to keep in mind when doing this trick. When sliding the cards onto the pile, make sure you don't tilt the cardboard...

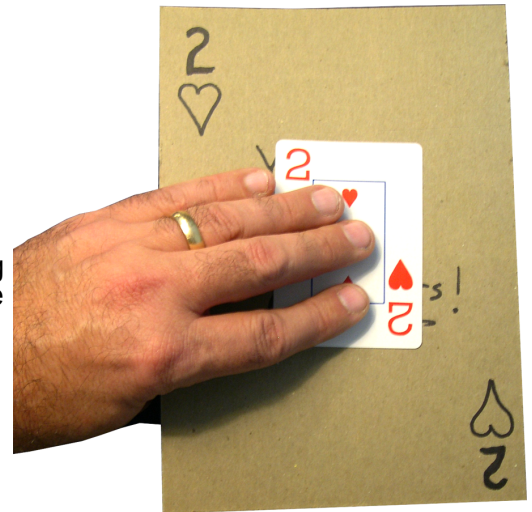

people may get a glimpse of the card underneath. Practice this in front of a mirror so you can be sure the card is not showing.

Emphasize many times that you are not touching the cards, this will make the trick more powerful.

Wait until there are a few cards on the pile before you mention they can stop any time. If you tell them at the beginning of the trick, and they stop after one card... you have a problem.

If the pile gets messy to the point where there may be confusion as to which is the top card, ask your helper to straighten it out a bit. Remember, you don't want to touch the cards.

This is a great trick... practice and have fun with it!



# I Knew You'd Pick That

On the table are five cards and a folded piece of paper with a prediction written on it. The prediction is a secret, only you the magician know what it is.

Through a process of elimination, the cards are narrowed down to just one. When the prediction is opened up, it matches the chosen card. It seems that you can see into the future!

## Here is the secret:

This is a useful technique for making the audience think they are choosing the card. In fact, it's the magician that makes the choice... which is why this technique is called "Magician's Choice".

Before the trick begins, you need to know which card you want the audience to pick. This is your "force card". Since they're face down, make sure you remember where it is on the table top.



Start by asking your audience helper to "point" to two cards. Don't say "pick" or they may pick up two cards which could spoil the trick.

Now you have two choices to make here, and this is where the secret of the trick comes in.

If your "force card" is one of the two pointed at, then place the other three cards into a pile on the side of the table. Leave your force card and the other one where they are.

If neither of the two cards pointed at is the "force card", then put those two cards onto the pile, leaving three untouched.

In other words, the helper does have a free choice of cards.... but you decide whether the cards stay or go.

There are now two or three cards left on the table. This time ask the helper to point to just one card.

Again, this card stays or goes depending on whether it's the force card. If it is the force card, move the remaining cards to the pile and leave the force card where it is.

If it's not the force card, move it to the pile and ask the helper to point to another card.

Eventually there will be one card left on the table. This is the force card. Turn it over so everybody can see.

Now have the helper unfold the prediction and show that they match!

Of course, this trick could be done with items other than cards. Three to five objects work best. Any more or less and you run the risk of the audience figuring it out.



# Think of Any Number

Have a spectator choose any number between 1 and 63. Tell them to write it down and put the paper in their pocket.

Claim that you can tell what the number is by listening to the tone of their voice as they answer yes or no to the following questions.

Close your eyes (or put on a blindfold if you want to get extra fancy) and show them the first of these cards. Ask if their number is on the card. When they reply, pretend you are really concentrating. Show the next card, ask again. Do this for all 8 cards. When done, pause and then announce in a loud clear voice what number they picked... it's correct!

## Here's the secret:

Notice the first number of each card, in the upper left corner.  $1 \cdot 2 \cdot 4 \cdot 8 \cdot 16 \cdot 32$ . These are special numbers, each double the one before it. Ask your math or computer science teacher, they can explain more about them.

All you have to do is add the special number on each card that the spectator replies "yes". For instance, let's say the chosen number is "45". The spectator will answer "yes" for cards 1, 4, 8 and 32. Add these numbers together and you get.... 45. As you are showing the cards, you'll need to know what the special number is on each one.

<b>1 3 5 7 9 11 13 15</b> <b>17 19 21 23 25 27 29 31</b> <b>33 35 37 39 41 43 45 47</b> <b>49 51 53 55 57 59 61 63</b>	<b>8 9 10 11 12 13 14 15</b> <b>24 25 26 27 28 29 30 31</b> <b>40 41 42 43 44 45 46 47</b> <b>56 57 58 59 60 61 62 63</b>
<b>2 3 6 7 10 11 14 15</b> <b>18 19 22 23 26 27 30 31</b> <b>34 35 38 39 42 43 46 47</b> <b>50 51 54 55 58 59 62 63</b>	<b>16 17 18 19 20 21 22 23</b> <b>24 25 26 27 28 29 30 31</b> <b>48 49 50 51 52 53 54 55</b> <b>56 57 58 59 60 61 62 63</b>
<b>4 5 6 7 12 13 14 15</b> <b>20 21 22 23 28 29 30 31</b> <b>36 37 38 39 44 45 46 47</b> <b>52 53 54 55 60 61 62 63</b>	<b>32 33 34 35 36 37 38 39</b> <b>40 41 42 43 44 45 46 47</b> <b>48 49 50 51 52 53 54 55</b> <b>56 57 58 59 60 61 62 63</b>

Copy this page onto heavy paper, then carefully cut out the cards above. Ask an adult to help.



## Helpful Hints... Magician Ethics

What is ethics? It's like good manners, in this case a way of acting around other magicians.

If you see a magician do a good trick, don't ask them how they did it. Just because you're a magician doesn't mean they have to tell you how it was done. If you can talk to him/her later, tell the magician you really liked the trick. Mention that you are a beginning magician, and you would like to know where to find the trick he did. Most magicians are more than happy to help beginners.

If you are watching a magic show with a lot of other people, and you see a trick that you know, DON'T say you know how it was done. You may think this makes you look smart, but it is actually very rude. People are at the show to have a good time, not to find out what tricks you know.



# Reading with Your Fingers

What if you could read with your fingers? This trick shows that you can. Three people write their names on a piece of paper, a girl and two boys. The paper is then torn in three pieces, and the pieces are dropped into a box or hat. With a blindfold on, the magician is able to pull out the one girl's name.



Here is how it works. The paper is folded into three parts, and the names are written on the paper, like the picture. Now tear the paper at the folds, and drop the pieces in the hat. Cover your eyes with the handkerchief, and reach into the hat.

Of course, this could be done with two girl names and one boy name, or two people wearing shoes with laces and one with velcro shoes, or two people who take the bus to school and one who walks.

How do you tell which one is the girl's name? Feel the edges of the paper carefully. The name in the middle will be the only one with two torn edges. The top and bottom names have only one torn edge. Pretend you're thinking hard, and people will think you can read with your fingers.

# Mystical Mobius

With the use of a long strip of calculator paper, you demonstrate a very strange version of reality.

By taping the ends together as in Figure 1, and cutting down the middle, you will end up with 2 loops of paper. That is expected.

Again, you tape the two ends together of another strip of paper, and cut down the middle... but now the loops are linked!

The third time, you cut down the middle and end up with one large loop!

How does this happen?

As seen in figures 1,2 and 3, the number of twists in the loop makes all the difference.

The first loop has no twists when you tape the ends together. It helps the effect of the trick a lot to do this regular loop first. The audience can see and confirm that cutting down the middle does what is expected... results in 2 loops.

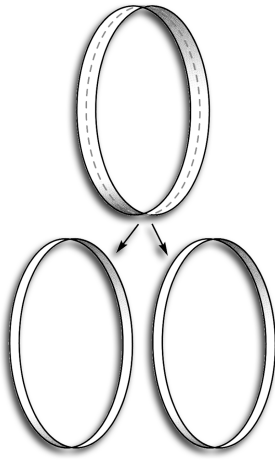

Figure 1

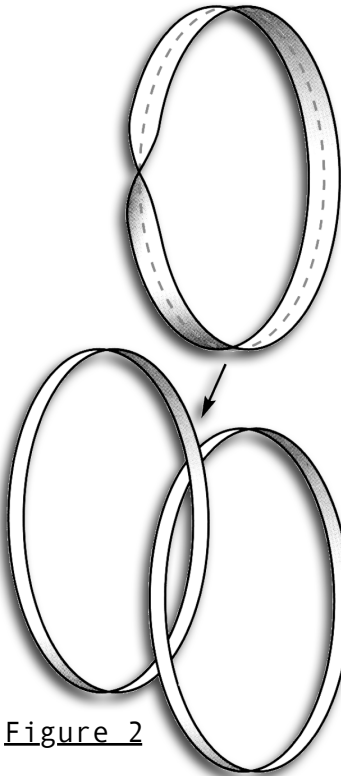

Figure 2

It does help to have the dotted line drawn on the paper strips before starting. This can be done easily by laying the strip of paper on a table, putting a book at each end to hold it in place, then carefully drawing the line with a pencil and a yardstick. The line does not have to be dotted. It could just be a straight line.

Use safety scissors, and have an adult help. Or you could just tear the paper. Some papers will tear in a straight line, as well as certain cloths. You could make the loops from old newspapers, they are usually able to tear in a straight line. Make sure to get permission of course.

However, the second loop is twisted before taping the ends, but the audience must not be aware of it. See figure 2. This is easy to accomplish, because the length of the paper strip hides any twists. When preparing for this trick, have the strips of paper laid on the table with the twists in place ahead of time. This makes it easier to proceed with the trick. If you want to make the twists while taping the ends, you'll need to practice the move until it is done very smoothly. Telling a story of some sort will help keep attention away from the paper while you are making the twists.

The third strip of paper has two twists, as seen in figure 3. Again, cut down the middle.

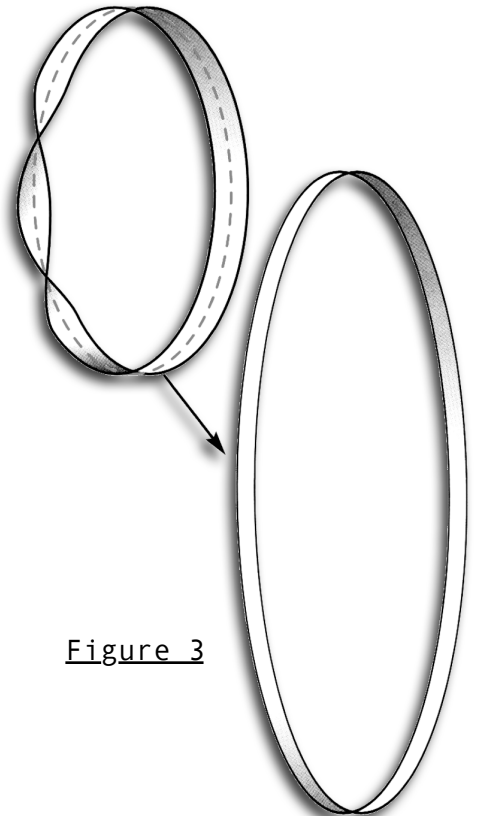

Figure 3



# The Gravitational Coin Transposition Trick



**With two hands and four coins, you can make one coin travel thru the space between your fists and appear in the other hand.. is it teleportation?**

This is what the audience sees: You show four coins and your two hands, like the picture above. Two of the coins go inside your fists.



The other two are placed on top of your knuckles by somebody from the audience.



After a bit of explanation about the effects of gravity on the coins, you pause and have the audience say the magic words. Upon opening your hands, one coin has traveled across!



**Here is the secret:**

During your "explanation" about gravity, you appear to drop the two coins from your knuckles to the table. Asking the audience helper to place them back on your fists, you continue on with the trick.

In fact, the helper has just done the trick for you!

When the audience sees two coins fall to the table, they assume it is the coins that were on your knuckles. That's the secret to this trick.

When turning your fists over, the left fingers grab the coin on top and hide it in the fist. This is relatively simple.

The right fist, however, does something totally different. It drops the coin from the top of the knuckles AND the coin from inside the fist. It must be done without visibly opening the hand.

By turning your fist sideways, you can hide the opening that allows the coin to fall out. This photo shows it from the magician's point of view:



This is not an easy trick to do. It takes a LOT of practice, especially in front of a mirror. You must be able to do the moves without even thinking about it.

The timing is also important. It must seem like the trick hasn't started yet when the two coins fall onto the table top.

For instance, you could say... "This trick that I'm about to do works by gravity. You know what gravity is, right? That's when things fall". Now drop the coins onto the table top. "Like that. Would you please put those back on my knuckles.... thanks."

Once those two coins are back on top of your knuckles, the audience thinks the trick is just starting. In fact, it's basically over. All you have to do is grab the coins from your knuckles and hold them in your fists.

Hold your fists wide apart, and move slowly. Any fast motion at this point would make the audience very suspicious.

Keeping the fists apart, move them slowly up and down. With a slightly faster upward move, grab the coins into your fists, then bring them back down and hold still for a moment. This pause is very important.

Now slowly open your fists to show three in the left, and one in the right.

Again, this trick takes a lot of practice. But it's worth it. This is a great effect, and if done well, will fool everybody!

Of course, you're not limited to coins. You could also use game chips (like in the photos), pebbles, small wrapped candy, any four objects that look alike and can fit in your hand.

# Mailing a Coin by Magic

Deciding to mail a valuable coin to your friend the collector, you wrap it up for shipping. To make sure it gets there quickly, you send it via magic express.

This is what the audience sees: You show everybody your valuable gold coin, and wrap it up in a piece of paper. After saying the magic words (with help from the audience), you tear the paper into small pieces and the coin has disappeared!

**Here is the secret:**

It's all in the way you fold the paper, plus a bit of sneaky misdirection at the end.

Start by placing the coin on the paper like in the photo below:

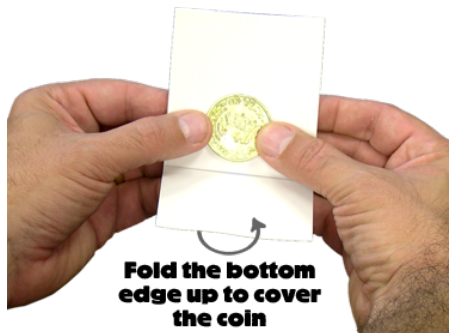

When you fold the bottom edge up, the coin should not be visible. Make sure it's not peeking over the top.

Crease the folds as you're making them, and be as even and precise as possible. In this trick, neatness counts.

Both edges should be folded in the same direction. Away from you, towards the audience.

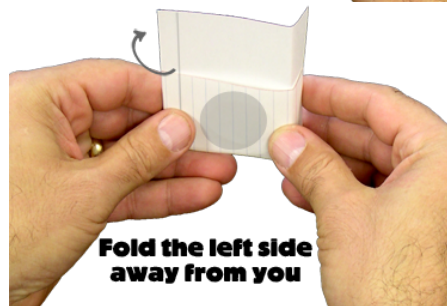
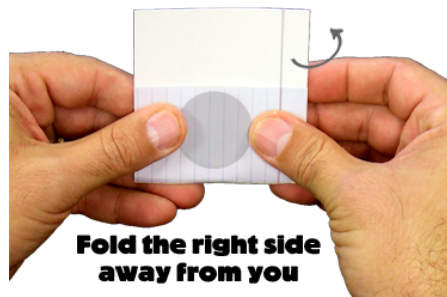

This next fold is the one that makes this trick possible. You want it to look as though you were folding the top flap of an envelope. You could even pretend to lick it. Don't really lick, just pretend. If you did lick the paper, that would be icky and you may get a paper cut on your tongue. Ouch.

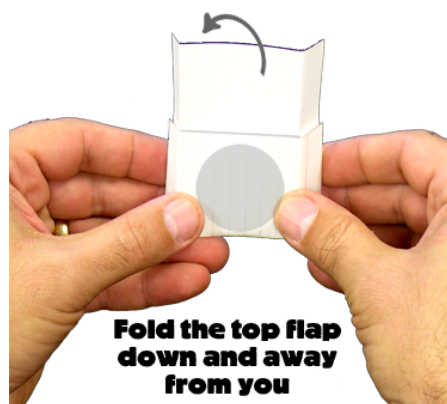

Notice how that fold creates a "pocket" in the paper where the coin is hiding. Don't let the audience see the opening. They should think that the coin is covered and sealed inside. In fact, the pocket is open at the top, allowing the coin to fall out.

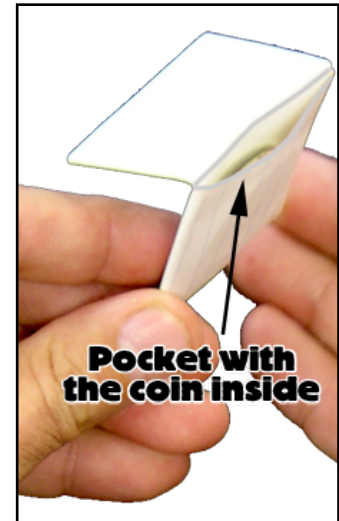

Which is exactly what you want it to do, but without the audience knowing about it of course.

By using misdirection, make them look at something else for a moment, just long enough for the coin to drop into your hand.



With that same hand, hide the coin while reaching for your magic wand. Drop the coin behind something or in your pocket, grab the wand and wave.

Pause, look at the paper, then slowly tear it into little pieces showing that the coin has disappeared!

# Pulling a Coin thru a Hanky

Causing a solid object to pass thru another solid object is a popular theme in magic tricks. Here is a fun way to demonstrate this using just a handkerchief and a coin.

*This is what the audience sees:*



Show your audience a coin in your hand. You cover this coin with a cloth napkin or hanky, then show everybody that it's still there. Perhaps they think it's going to

disappear. Twisting the bottom of the hanky, you ask somebody to hold it tight. As if by magic, you slowly pull the coin right thru the cloth... and show there is no hole in the hanky!

**Here is the secret:**

You don't actually pull the coin thru the hanky.... that would make a hole, and it would not be much of a trick. However, by wrapping the coin in a special way, you make it look like it's in the middle of the cloth. The coin is actually outside the hanky, near the edge. Here's how.

Hold the coin like you see in the photo above. This position is important, so make sure you're hand matches the photo. Your hand will stay in this position for almost the whole trick.

Now cover the coin with the hanky, making sure the coin is in the middle of the hanky. Again, this is important. If you want, you could have an audience helper place the cloth over the coin. Anytime you can get an audience helper, it makes the trick more interesting to them.



Now come the super duper secret move of the universe.

While straightening out the hanky, you pinch some of it between your thumb and the coin. The photo above is from the magician's point of view. In other words... it's what you see, NOT what the audience sees.

Reach over the top of your hand, grab the bottom of the cloth closest to the audience, and lift it up to show that the coin is still there.



Drape the hanky over your wrist, and straighten it out. Make sure there are no wrinkles or extra folds. Again, the photo above shows how it looks from your point of view.



It's time to cover the coin again, so lift both layers off of your wrist, and place them over the coin. It should look like the photo above (from your point of view). Notice that the coin is now on the outside of the cloth, and is only hidden by the fold in the middle. Make sure the audience does not see this part. Straighten everything so it looks nice and neat.

Now hold the coin with one hand, then grab the bottom of the hanky. Ask somebody to hold the hanky tight, making sure they don't see the coin peeking out from under the cloth.



You hold the coin in your fingertips, and slowly pull it out from under the cloth. It will appear like it's being pulled right thru the hanky by magic!

# Vanishing a Coin

**Sleight of hand magic - using pure skill to bring about a magical effect. With cards, coins, ropes and other small items, the magician can perform apparent magic.**

**It takes a lot of practice, and you're fingers may be doing things they've never done before. When you see a skilled sleight of hand artist perform, you may think it looks easy. It's not. But even though it's hard, it's worth it. Practice is the key.... lots of practice!**

*This is what the audience sees:*

A coin (or any small object) is shown to the audience. Placing it into the other hand, and making a magical gesture, the hand is opened to reveal that the coin has vanished into thin air!

## **Here is the secret:**

You don't actually put the coin into the other hand.

That may sound simple, but there is a lot more to it than that. While it's true that you keep the coin in the first hand, it has to look like it went into the second hand. There has to be no doubt in the audience's minds that the coin is in the other hand. Here's how.



First hold the coin just like in the photo above. This is a natural way to hold a coin, and looks quite ordinary.



Next step, actually place it into the other hand, and close your fingers around it. Nice and simple. Do this over and over, until it seems like you're not even thinking about it.

Now that you're tired of putting it into your hand, let's do it a bit different this time.

When you are turning your hand over to place the coin into your second hand, hold the coin with your thumb so it stays in your first hand. Keep your thumb on the coin for the rest of the trick, with your fingers flat.

Now pull your first hand back, still holding the coin, and close the fingers of the second hand at the same time. This should look just like it did when you were putting it in your hand over and over.

Notice how the fingers are loosely closed in the photo to the left... it looks like something is in there.

Notice how the fingers are closed in the photo below.... it looks like you're about to punch the audience in the nose (which is not a nice way to treat them). Make sure you close your fingers loosely.



To really make the audience believe the coin is in the second hand, look at that hand and move it up a little. Keep your focus on that hand. What about the first hand that is actually holding the coin? Let it drop down to your side, as though it was not even there. Don't think about it, and NEVER look at it.

Say the magic words, pause, then open your second hand.... the coin has vanished!

# The Upside Down President

Borrow a dollar bill from somebody in the audience. Or maybe a twenty dollar bill... ask for a hundred dollar bill if you want. Who knows, you might get one!

Hold it up so the audience can see the picture of the president on the front, and point out that he is standing upright. Fold the bill a few times, keeping it held steady and in full view at all times. When you unfold it, the president is now upside down!

## Here's how it's done.

This one takes a lot of practice, because the sequence of folds is important.

These photos are from your point of view, what you will see when performing this trick.

The bill is pre-folded, which makes it much easier to perform. There is also a dot drawn on the back of the bill. This helps you know which part to grab at a crucial move.

### Step 1:

While doing the folding, keep the bill as motionless as possible. Avoid moving it around anymore than you have to. The more movement you make, the more suspicious your audience will get.

Check with these pictures as you're folding to make sure it looks the same.

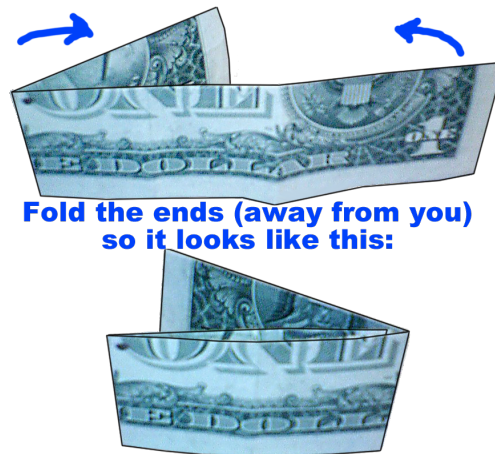

### Step 2:

At this point, it helps if you hold the bill from the top, where the letter "N" is folded in half. Use just your fingertips so it doesn't look like you're hiding something. Fold the left side first, then the right. Having the bill already creased helps a lot here.

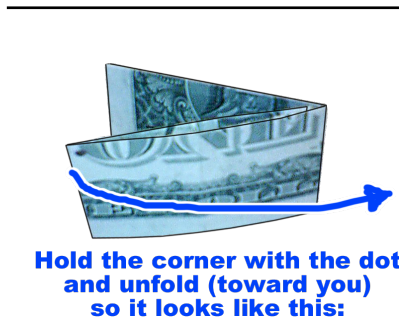

### Step 3:

Before unfolding the bill, do the "magic move". It's always fun to get your audience involved by having them say the magic word, wiggle their fingers, maybe even do a silly dance. Use your imagination!

This part of the trick is the most important. Make sure you are unfolding the bill just like it shows in the photos.

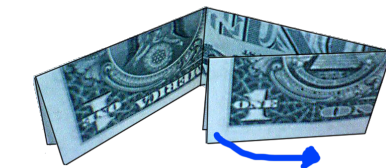

### Step 4:

The final move is where you reveal that the president's picture is now upside down.

If you finish and the president's picture is facing you, then try it again until you see the word "ONE" upside down.



# Rubberbands Are Jumping

While your audience is watching you stretch a rubber-band around your first two fingers, you talk about the famous Harry Houdini. No ropes could hold him, he always escaped.



Even when held tight (demonstrated by squeezing the rubber-band) he was able to jump right out. When you open your hand, the rubber-band has jumped to your other two fingers in the blink of an eye!



Here's how it works:

This is a very popular trick, and quite easy to do. Just pay attention to the photos and make sure your fingers are in the same position.

At the beginning you are stretching the rubber-band from one side of your hand to the other. This gets your audience used to seeing you stretch the rubber-band, and it helps to focus their attention on your hands.

Just before you close your fingers into a loose fist, you stretch the rubber-band down along your palm to your wrist. Make sure the audience does not see this part, so keep the back of your hand towards them. Also, keep the rubber-band against your skin, don't lift it up away from your palm.



Now curl all your fingers so they go inside the loop of the rubber-band. Keep your thumb out, and make sure all your fingers are inside.



Notice that the fingers are straight, not bent over like a fist. This is important.

Slide the rubber-band up your fingers a bit so it rests on your knuckles. Again, hide this from the audience.

All these moves should be practiced so they can be done in one smooth motion. Not fast, but smooth.

Once the rubber-band is in position on your knuckles, you are ready to do the magic.

Make sure the back of your hand is facing the audience, and they can see the rubber-band easily. Practicing in front of a mirror (which is always a good idea) will help a lot for this part.

Pointing to the rubber-band helps to focus the audience's attention. You want them to know that something is about to happen, and they better be watching. As usual, pause before you do the next move.

To make the rubber-band jump across, simply open your fingers. It's just that easy! Make sure your fingers stay straight. This happens very fast, which is why you want to make sure the audience is looking closely.

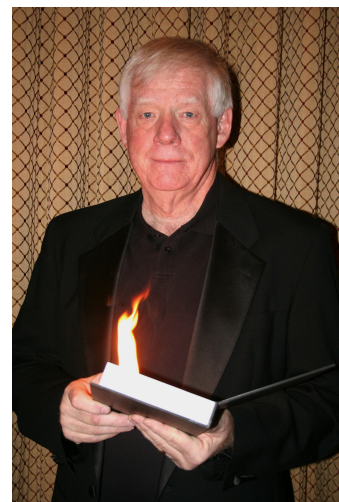

# From an Empty Box

After showing a box empty, you reach in and pull out... anything that will fit!

Many types of boxes will work, as long as they have a lid that is not attached. Look at the pictures on this page and you'll see why.



The item you want to produce, called the "load", is in a cloth bag. This could just be a square piece of cloth with the corners pulled up and tied with a string. That string is then attached to one side of the lid.

The lid is placed on top of the box, with the load hidden inside. Some of the pictures are an "x-ray" view so you may follow where the load bag is. Of course, the box you use should not be clear.

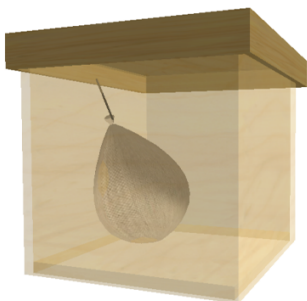

Begin with the box on your table. Slide the lid forward, towards the audience, keeping the load hidden.

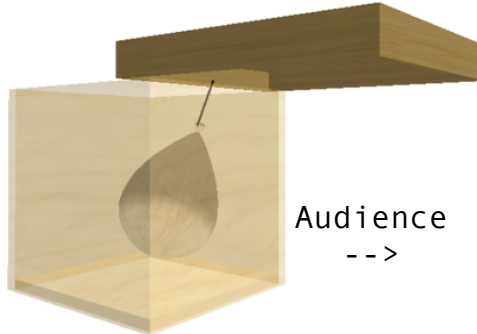

Drop the lid back down, then lift it up and back. As always, keep the load hidden.

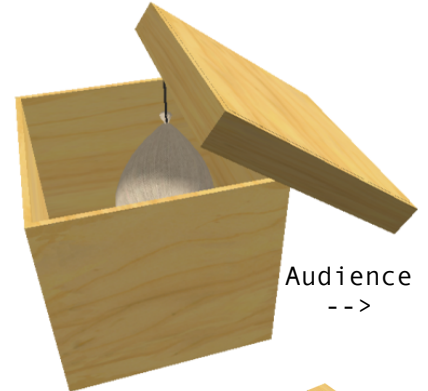

Turn the lid up, showing the inside of it. Rotate it if you want, showing the front & back of the lid. Make sure the string does not show. If the load is lightweight enough, a thin thread will work fine. Use a color of thread that matches the inside of the box.

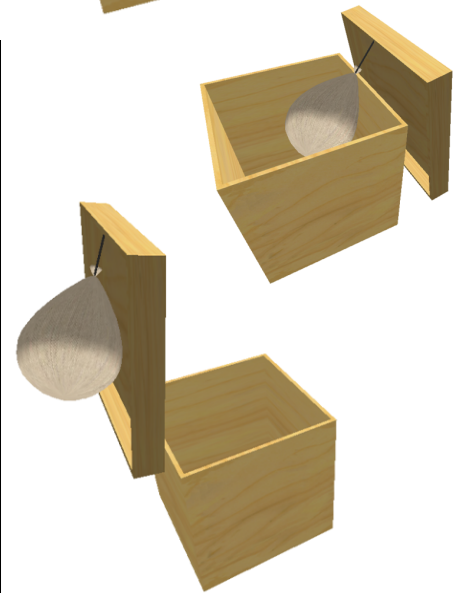
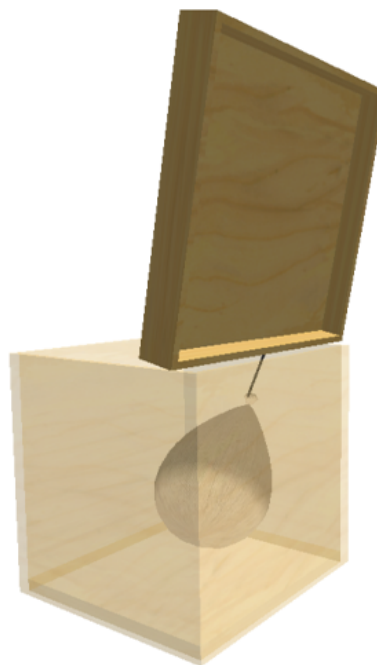

Once the lid is behind the box, tilt the box forward and show it's empty. To put the lid back on, just do these moves backwards. Then open the box and pull out the items!

Practice with a mirror, and practice often! Also, keep in mind where the audience is, so you know what they can see. If they are too far to your side, they will see the load. Figure out a way to block their view.



# Two Panel Production

Using 2 large sheets of cardboard and 2 performers, you can present an amazing production illusion.

Both sheets of cardboard are shown empty by the assistant, then placed together. When they are separated, a person appears between them!

Instead of cardboard, you could also use foam core. It's more expensive, but will last longer. You'll need to add supports to the panels so they can stand upright (unless you're using two assistants). The panels should be tall enough for a person to hide behind. Always slide them, don't lift them up to move. Downstage is towards the audience, upstage is away.

## The Secret:

Follow the illustrations, and you'll see it's all in the sequence and position of the panels as they are being shown empty. The assistant moving the panels is on stage left (wearing earrings in the illustrations), and the person who will appear is hiding behind the panel on stage right (wearing the hat).

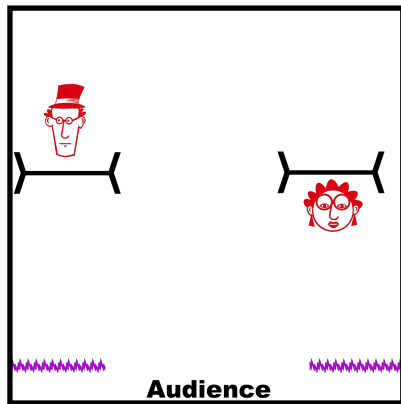

Position of panels at beginning of trick.

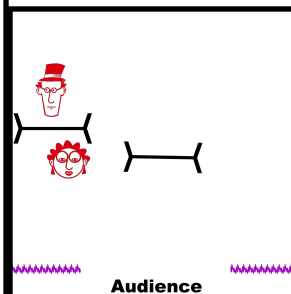
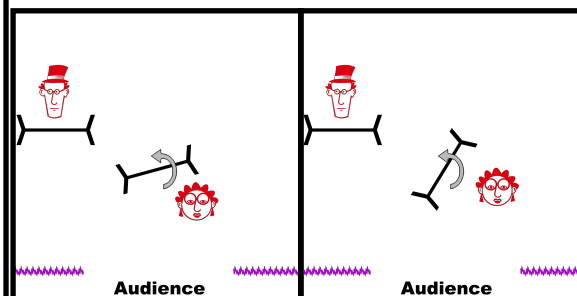
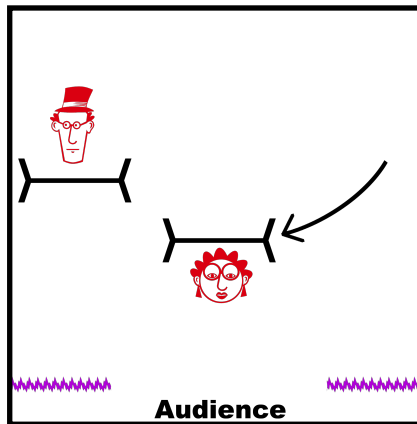

First panel moved downstage, then turned to show all sides. Assistant walks to second panel.

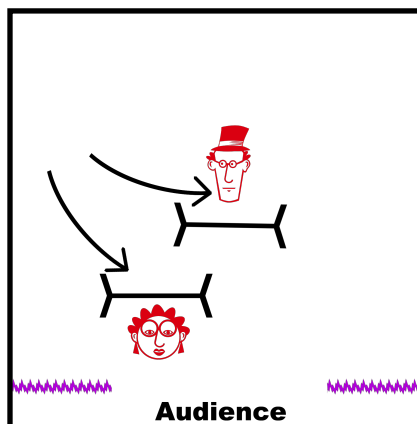

Second panel moved downstage, person moves behind first panel

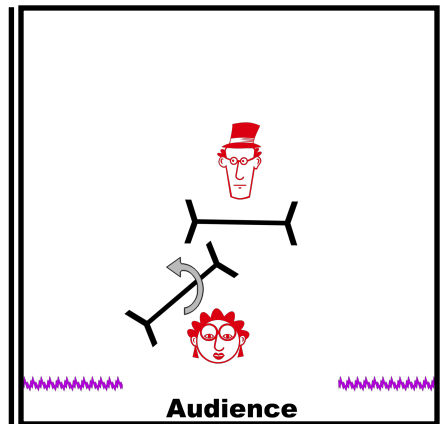

Second panel shown empty on all sides. Person stays behind 1st panel.

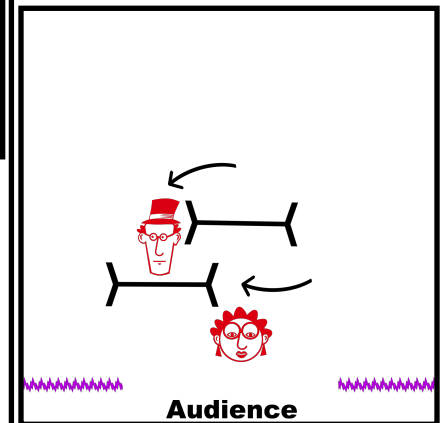

Second panel slid towards stage right, person moves behind it and hides.

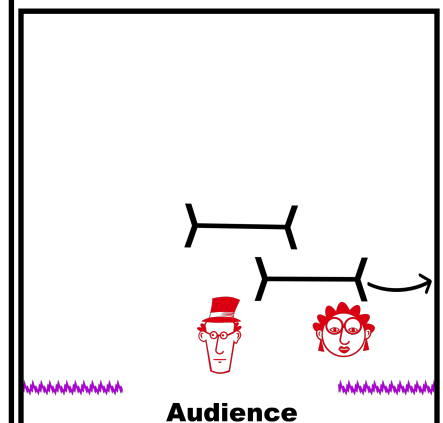

Panel slid towards stage left, person appears!

# My Pockets Are Full!

## Helpful Hints... Your Ideas Are Great

Now that you've read and tried a few routines, you may already be coming up with ideas of your own. GREAT!! The best thing to do, when you have a new idea, is write it down in a notebook. Even if it seems silly and could never work, write it down. That idea may spark another idea in your head that could become a great show.

Keep those notebooks. A magician in Atlanta started keeping notes in 1974. He now has enough material to write dozens of books and magazine articles, and develop lots of new shows.

Think about your idea, and try to picture it in your head. Now get the materials you need, and PRACTICE! You may know how to do the trick, but you still need to practice what you'll say, how you'll move, where you'll stand, everything that makes a routine entertaining.

When you're ready to perform for an audience, you'll feel confident and sure of yourself, because you will know exactly what is going to happen.

Once you begin collecting new tricks, and performing more often, you will need something to carry your show in. Since a beginning magician can hardly afford a \$300 professional model suitcase table, something cheaper will do. Actually, many professionals use suitcases that were bought at secondhand stores for \$3.

Look around, and you will find many possibilities for unique cases that will match your show and personality.

An old empty tackle box would work just fine. All those small compartments are perfect for holding cards, coins, rope, and any other items that you would use. You might also consider an old lunch box. It's rugged, easy to find, not too expensive, and you can have a snack after the show.



For a comedy act, something really different is in order. One magician uses a broken, dented garbage can to carry his props in. That might be hard for you to carry around, but how about a paper bag? To make sure it won't break, you should double-bag it (which makes a secret pocket in the side... good for certain tricks). An old shoe box with your name on the outside would look nice on a small table.

A perfect table for beginning magicians is a TV tray. They're lightweight, foldable, and sturdy enough to hold small tricks.

[www.JimStottMagic.com](http://www.JimStottMagic.com)

# There's Always More To Learn!

Many famous people started out as magicians: Steve Martin, Johnny Carson, Orson Wells, and Harry Anderson. Magic is very popular and FUN. Everyone knows the name of David Copperfield, magician. He made the Statue of Liberty disappear, as well as a jet airplane. David Blaine is well known for floating.

Try to watch magicians whenever you can. Read the TV schedule, and circle the shows that have them.

Some magicians tour with large stage shows. These are a real treat to see, and sometimes you may get to meet the stars backstage after the show.

There are many books about magic. Many can be found at your school or local library. Most magic books can be found around 793 in the shelves. Study them, and learn as much as you can about the fascinating world of magic. Also try juggling, puppetry, balloon animals, you could even be a clown.

Magician's clubs are all over the world. The two largest ones are the International Brotherhood of Magicians (IBM), and the Society of American Magicians (SAM). There's even a group for youngsters, The Society of Young Magicians. These clubs usually meet once a month. Call your local magic shop for more information, or check out their web sites.

**Study hard, keep practicing, and HAVE FUN!**



**Society of  
American Magicians:**  
[www.MagicSAM.com](http://www.MagicSAM.com)



**Society of  
Young Magicians**  
[www.MagicSYM.com](http://www.MagicSYM.com)



**International Brotherhood  
of Magicians:**  
[www.Magician.org](http://www.Magician.org)

## BOOKS

- **The Big Book Of Magic**  
Bill Severn.
- **Houdini, the Untold Story**  
Milbourne Christopher.
- **The Amateur Magician's Handbook**  
Henry Hay.
- **Funny Paper Magazine**  
[www.spsMagic.com](http://www.spsMagic.com)

An advertisement for Jim Stott Magic. The background is a red curtain. On the left, a man in a dark blue sweater and khaki pants is holding a red and yellow ribbon. In the center, a young girl in a pink shirt and a white party hat is holding a long, multi-colored ribbon. The text "EVERYONE LOVES THE MAGIC MAN!" is written in large, white, bold, sans-serif capital letters. To the right of this text, "Jim Stott Magic" is written in a smaller, red, sans-serif font. Below the main text, "Birthday Parties" and "Comedy Magic" are written in white, bold, sans-serif font. Below that, "Entertainment" and "Reasonable Rates" are written in white, bold, sans-serif font. At the bottom, the phone number "(270) 963-0850" and the website "www.JimStottMagic.com" are written in yellow, bold, sans-serif font.

**EVERYONE  
LOVES  
THE  
MAGIC  
MAN!**

**Jim Stott  
Magic**

**Birthday Parties      Comedy Magic**  
**Entertainment      Reasonable Rates**

**(270) 963-0850**  
**www.JimStottMagic.com**

Thanks for reading my book, *Learn Magic!* I hope you enjoyed the book and learned lots of neat tricks!

Remember to practice each trick before you show it to your friends and family!

Magic is a great hobby that you can enjoy regardless of your age. Have fun, enjoy, and thanks again!

Jim